

## Focus Ds

600x600, 1200x600, 1600x600, 1800x600,  
2000x600, 2400x600,  
625x625, 1250x625

**M206**

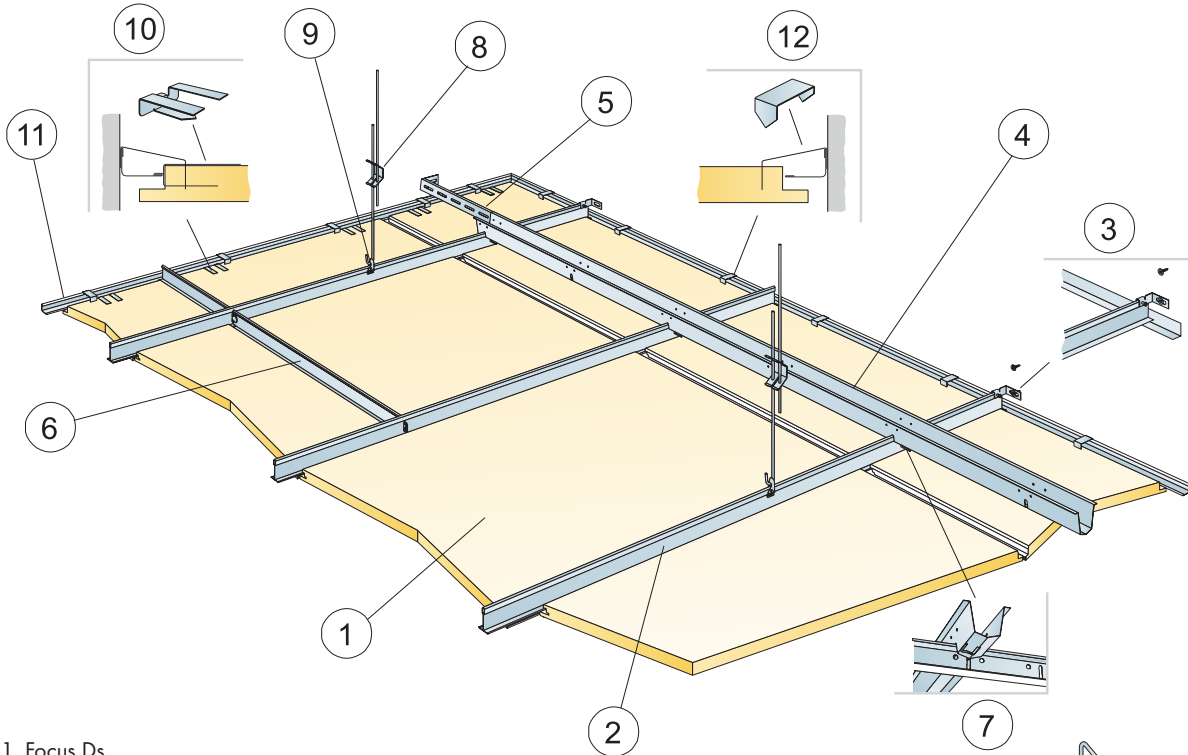
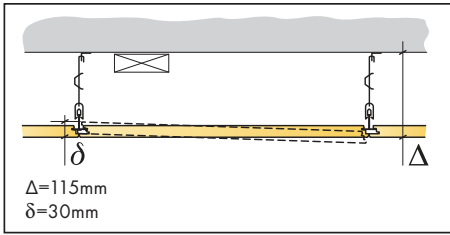

1. Focus Ds
2. Connect T-24 Main runner HD

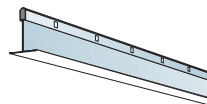

3. Connect Wall bracket

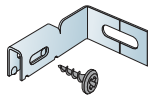

4. Connect Space bar

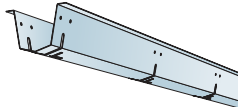

5. Connect Wall bracket

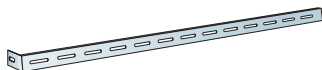

6. Connect T-24 Cross tee,  
L=600/625/24"

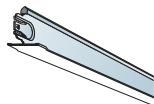

7. Connect Space bar winch



8. Connect Adjustable hanger



9. Connect Hanger clip



10. Connect Support clip Dg20

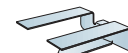

11. Connect Angle trim 15/22, fixed at 300  
mm centres

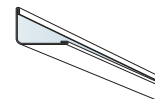

12. Connect Perimeter tile clip



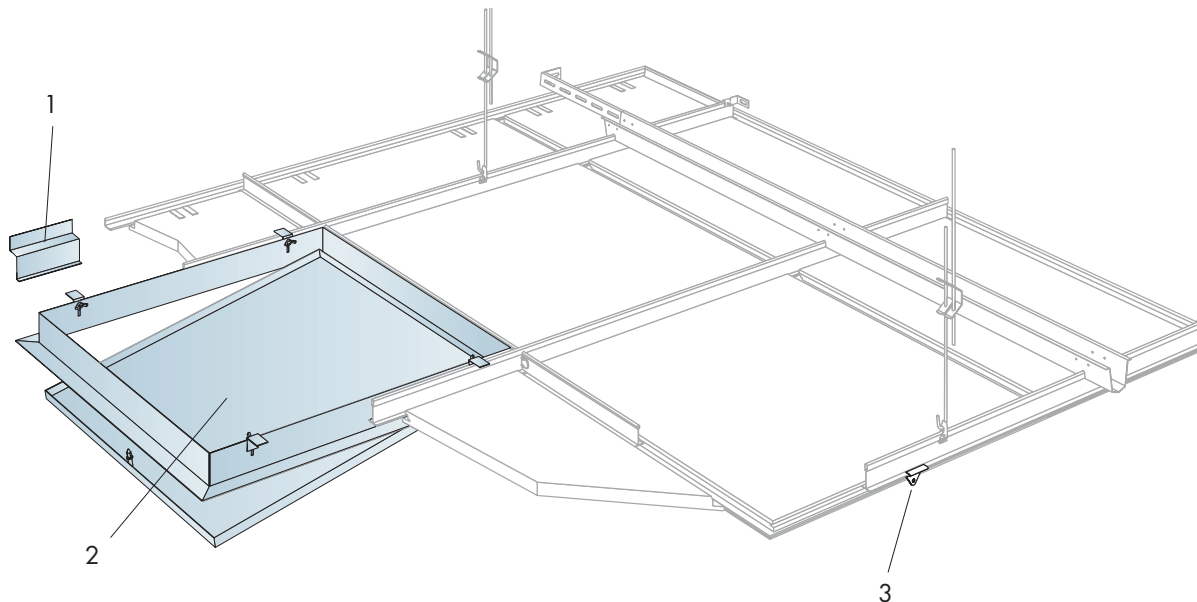

1. Connect Distance trim

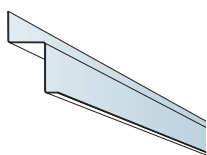

3. Connect Light fitting clip

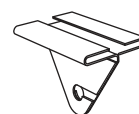

2. Connect Inspection panel

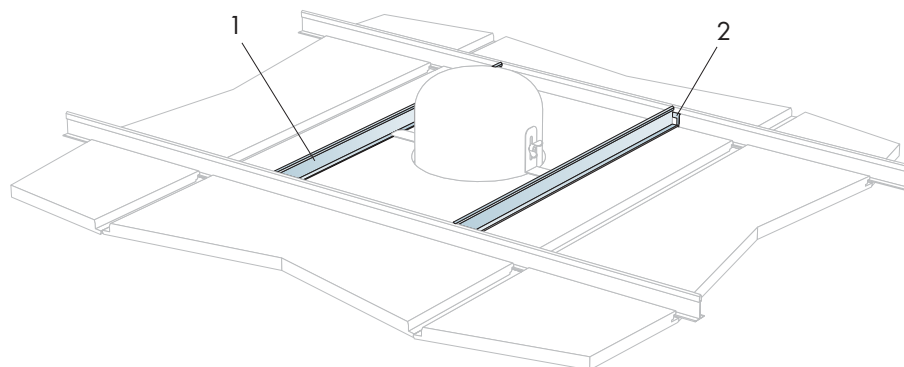
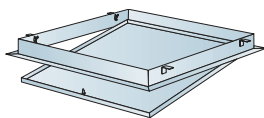

**→ 24**

1. Connect Bridging profile

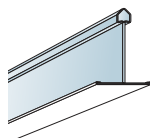

2. Connect Bridging clip 5/20

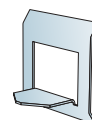

**Ecophon**  
SAINT-GOBAIN

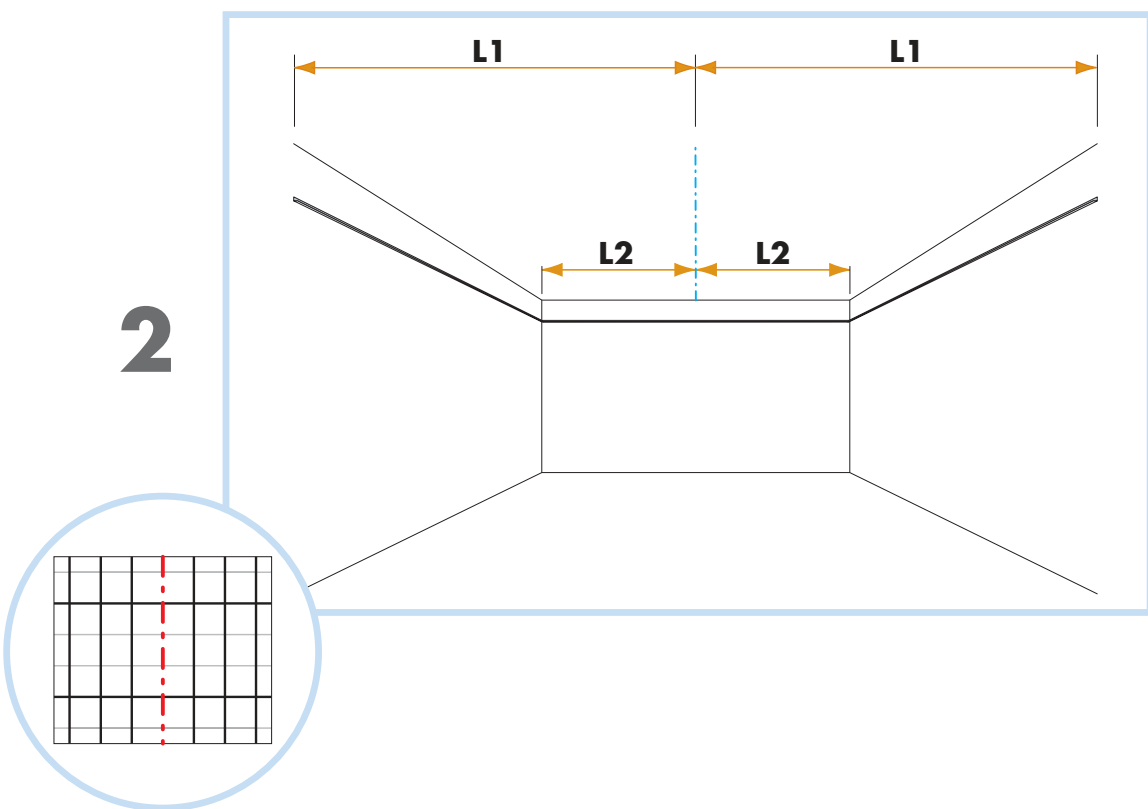
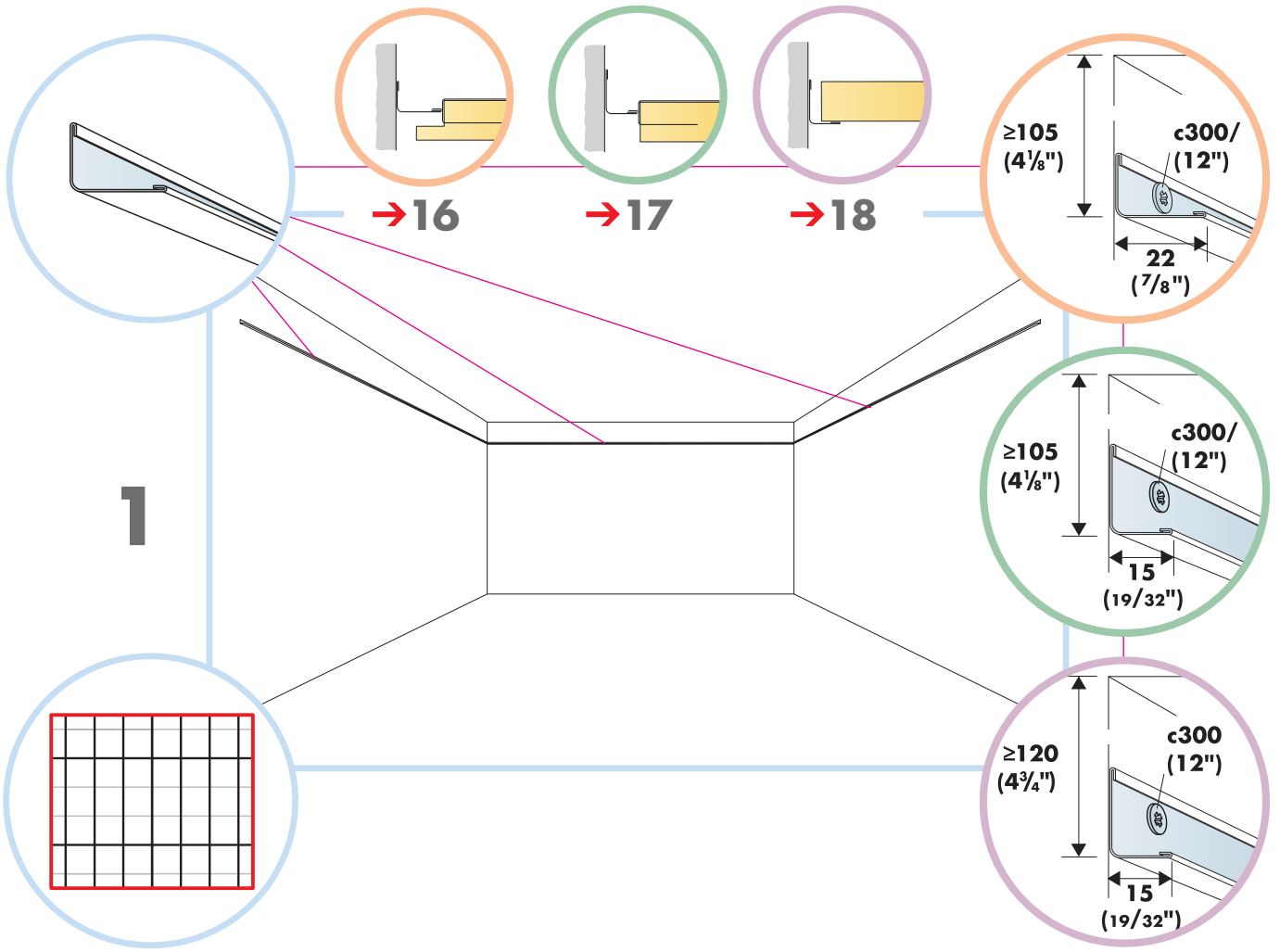

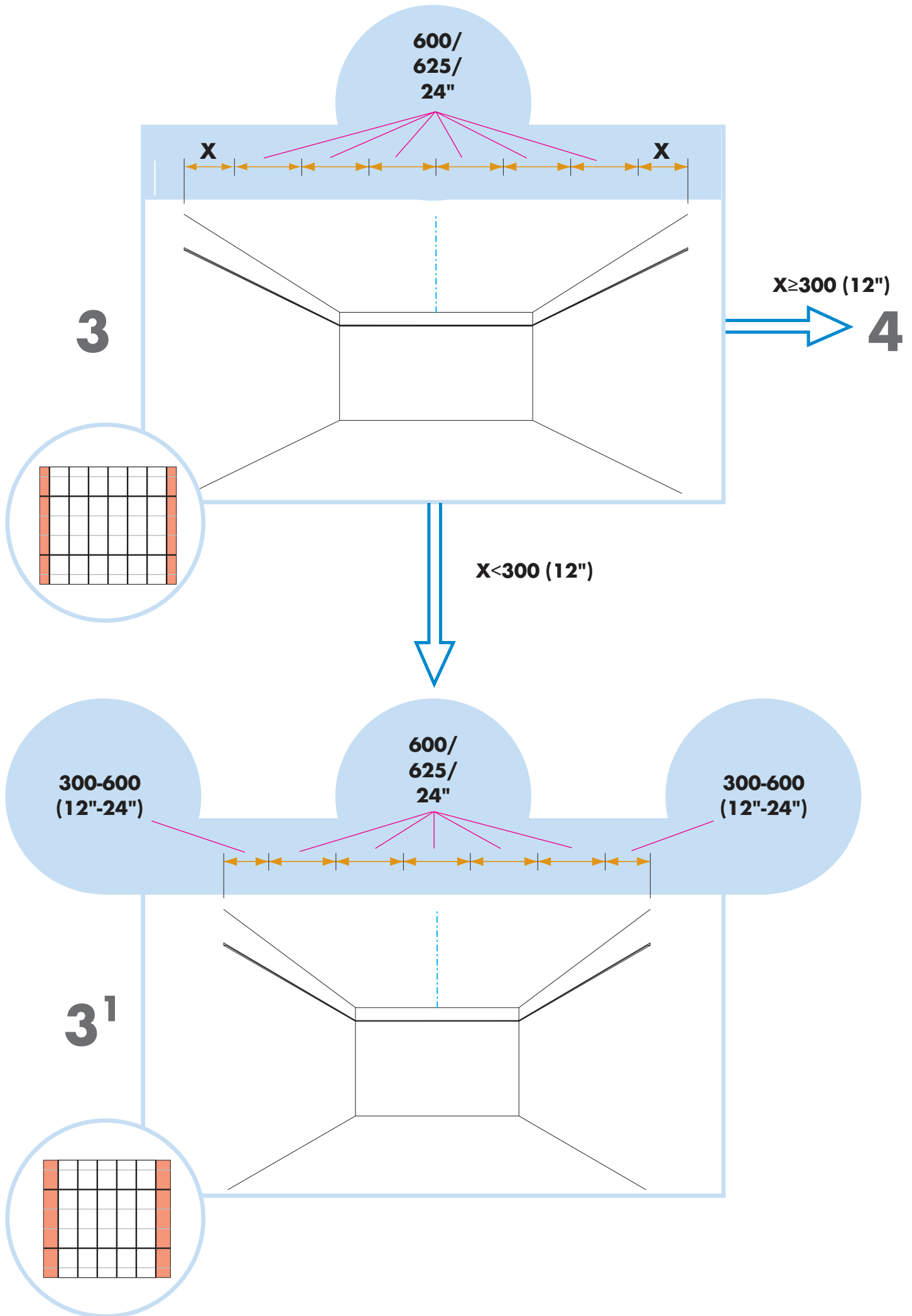

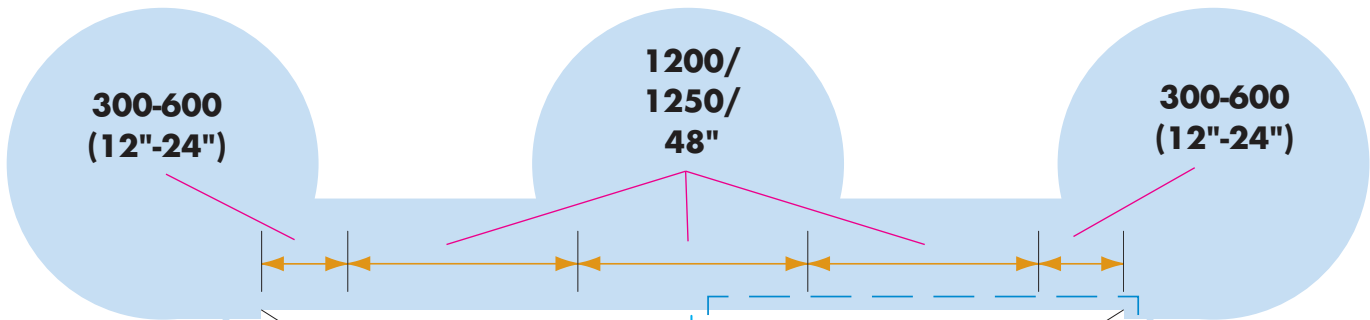

4

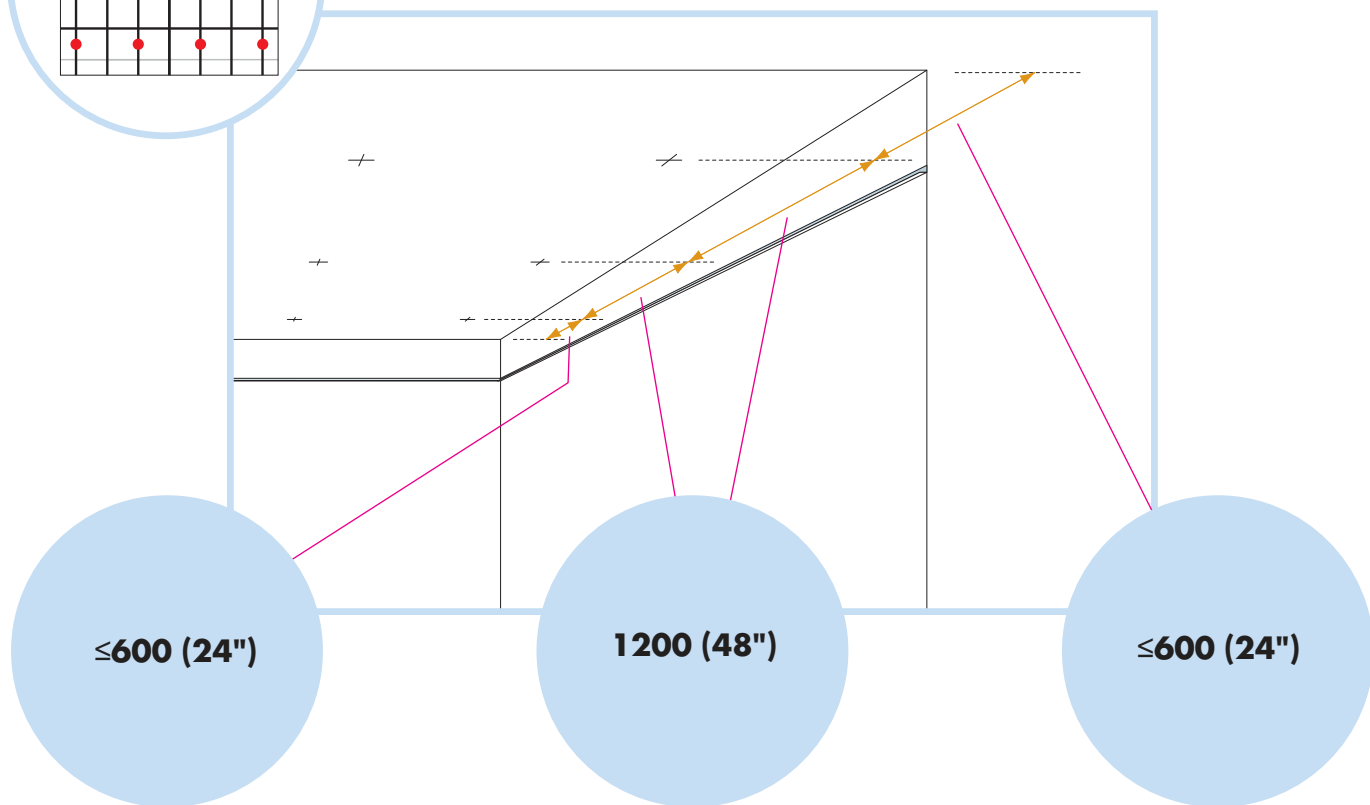
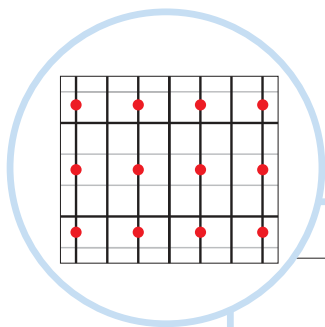
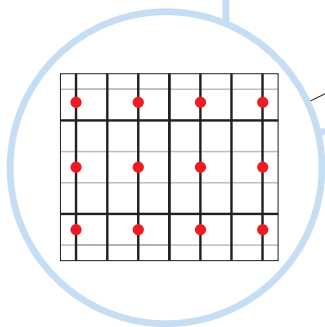

5

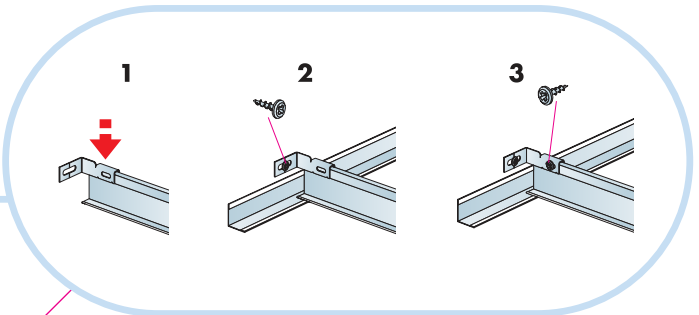
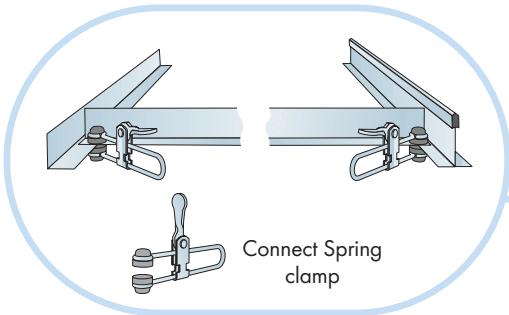
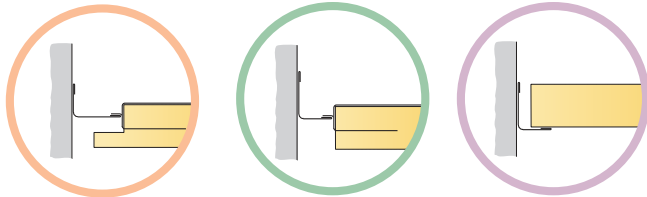
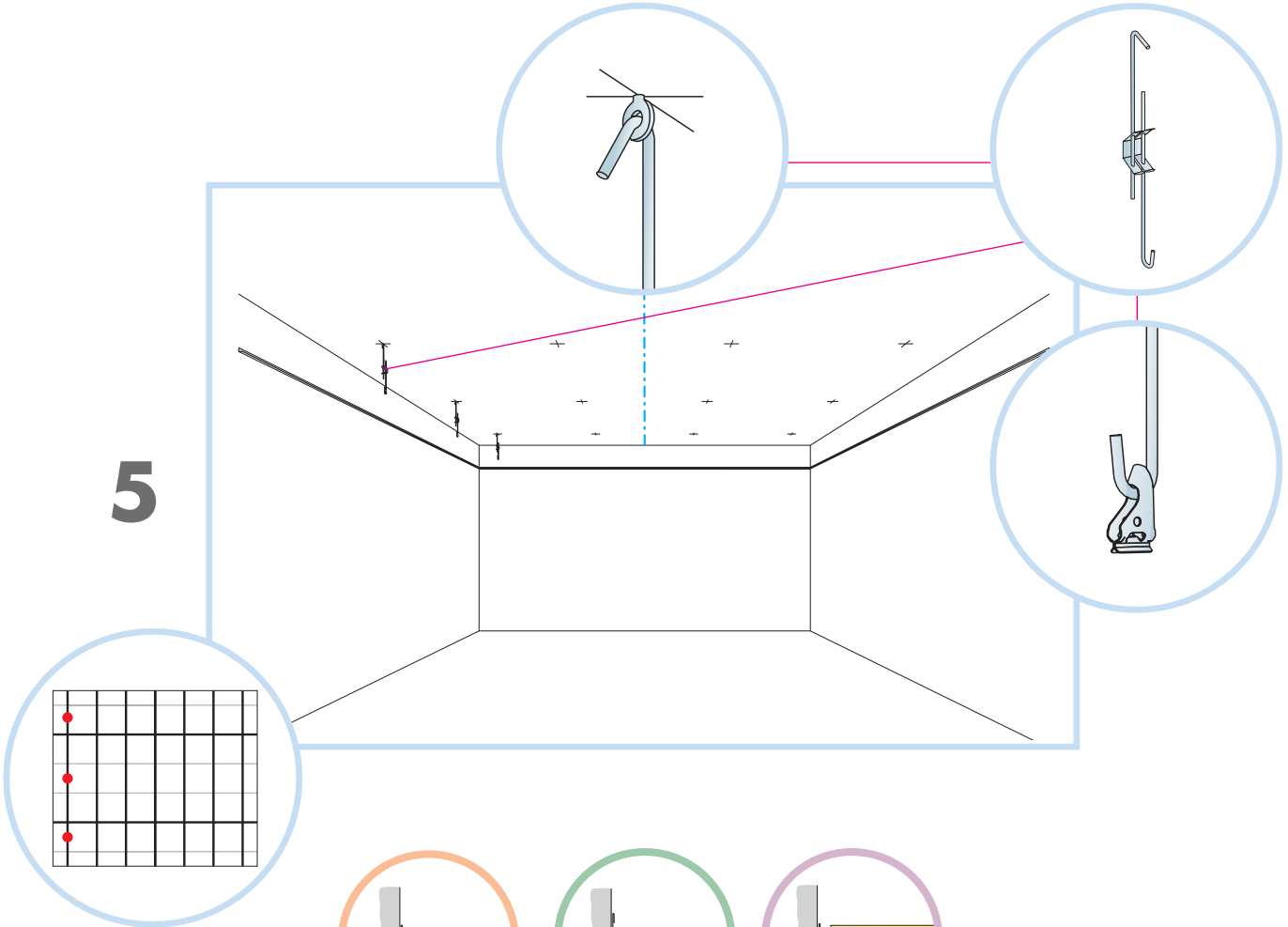

6

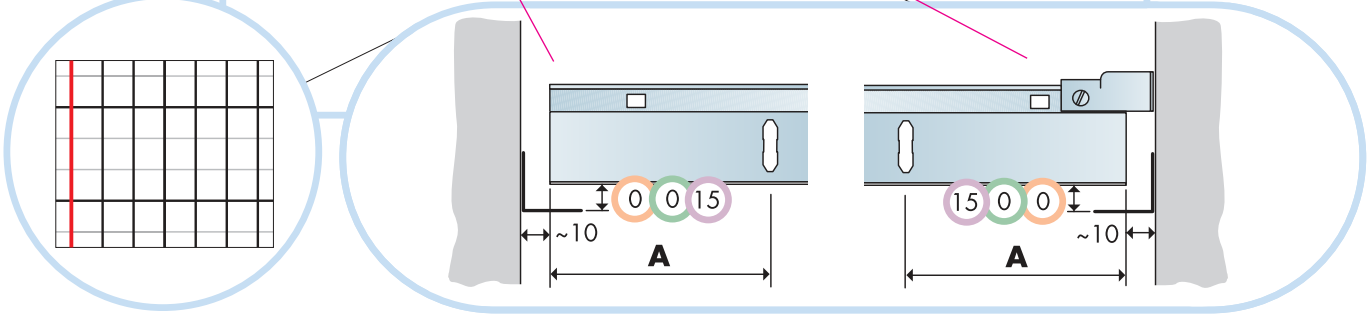
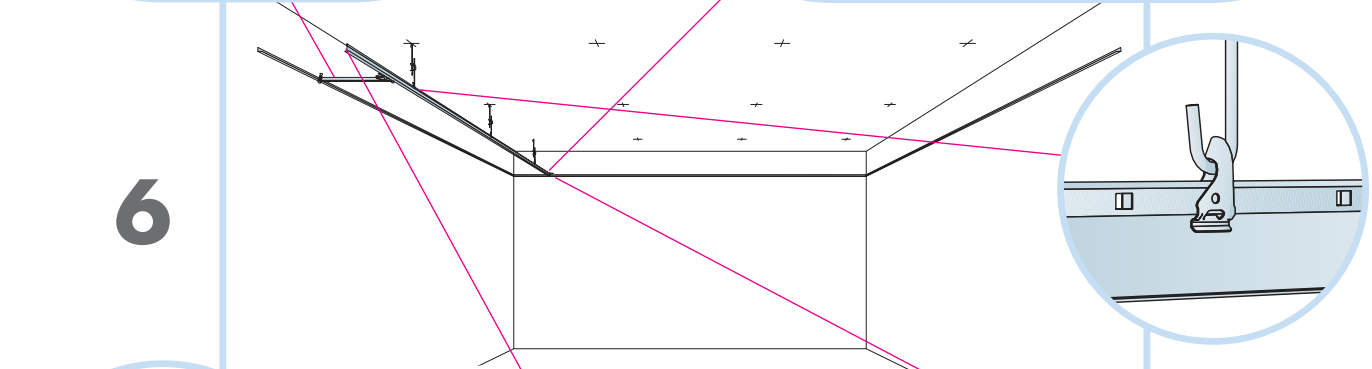

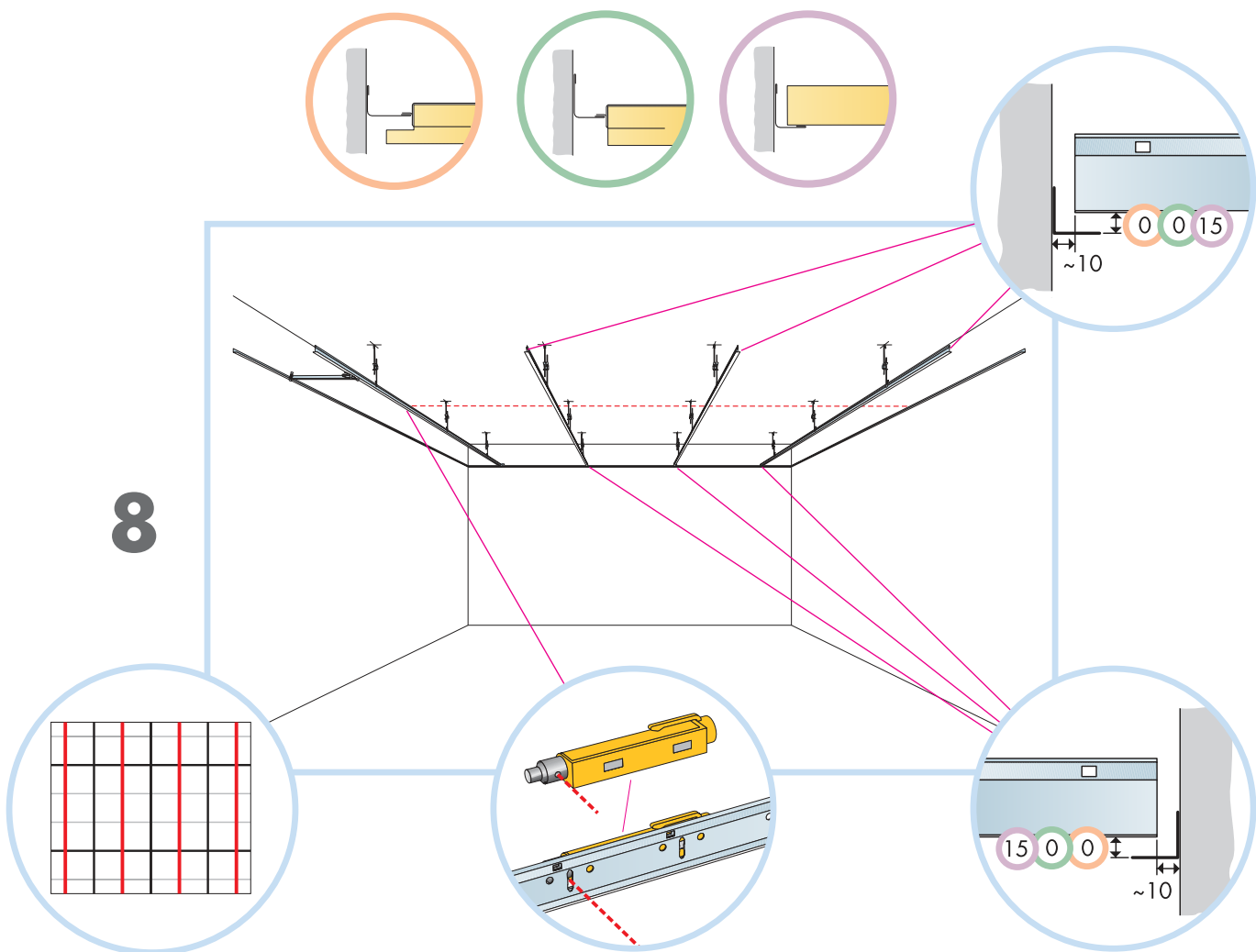
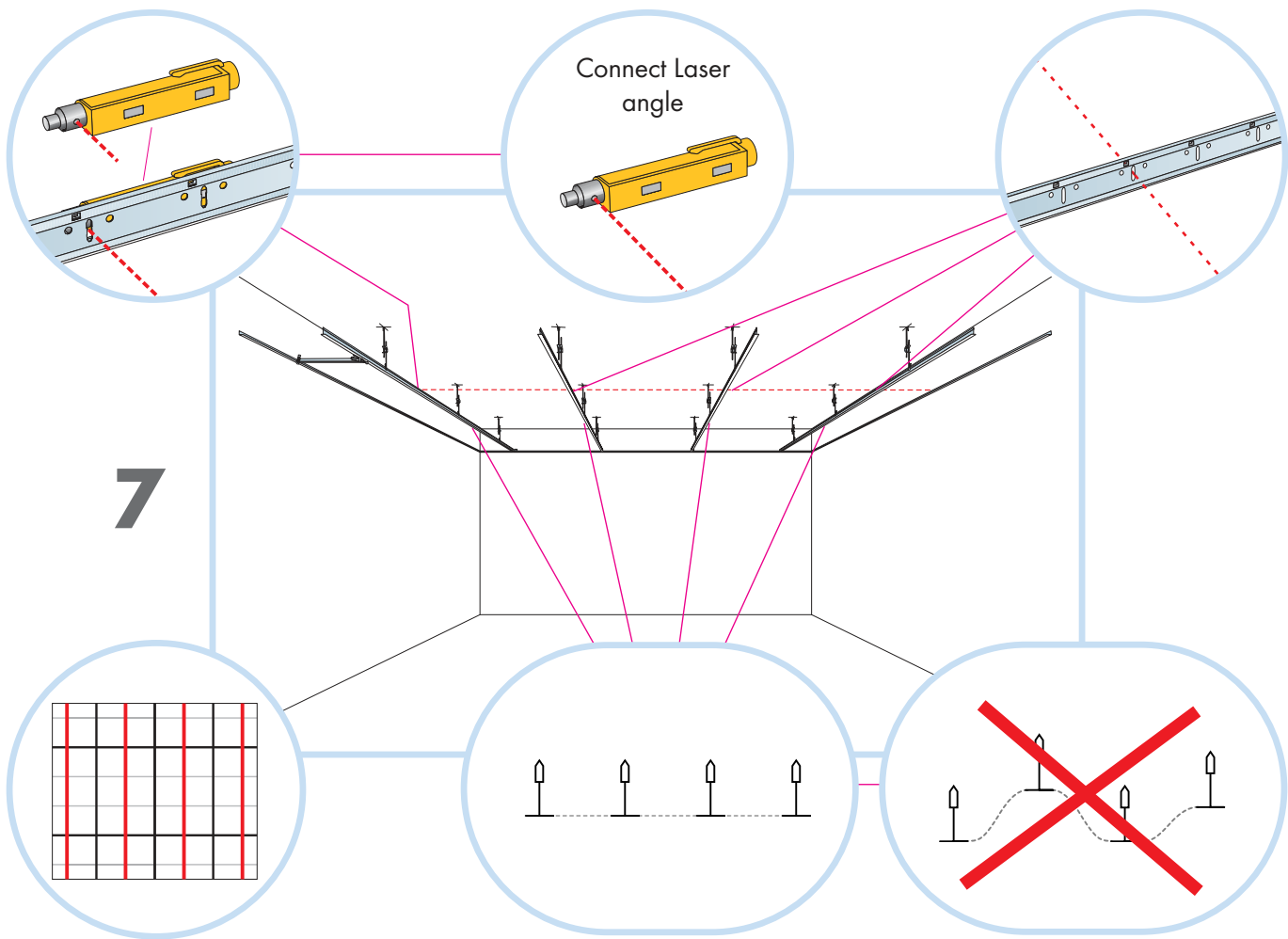

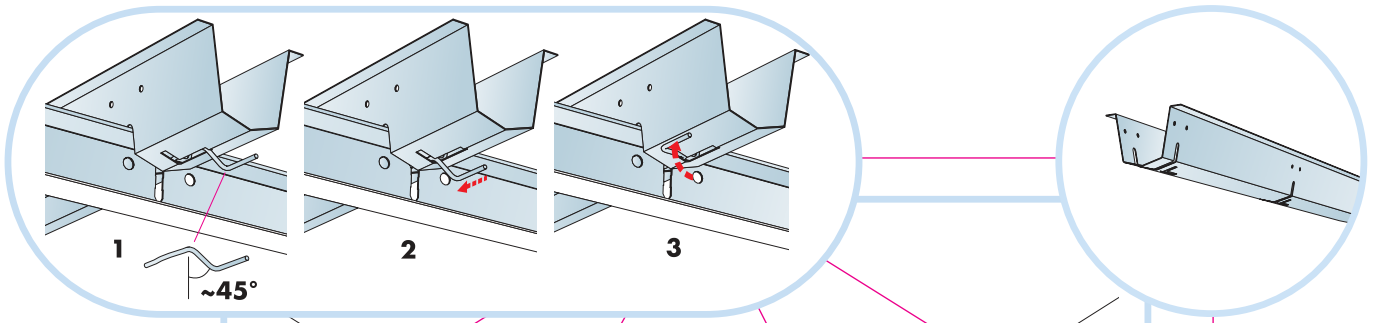

9

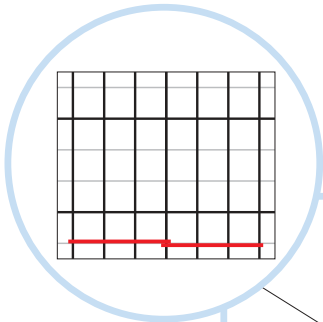
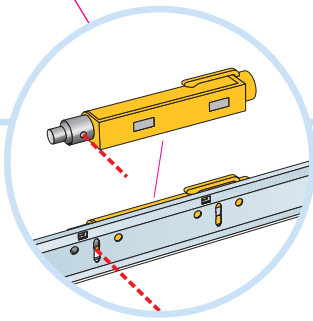
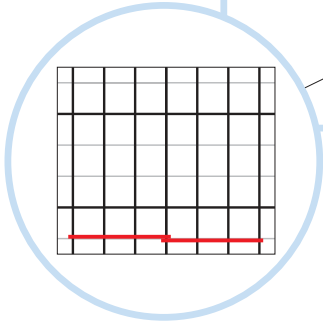
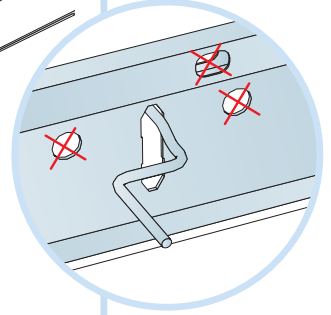

10

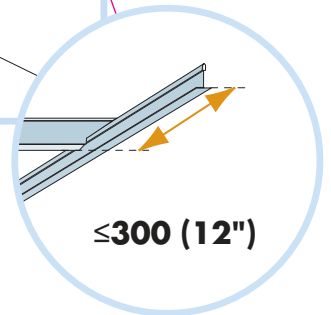
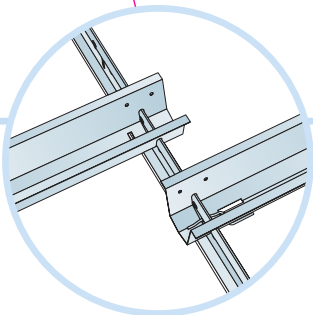
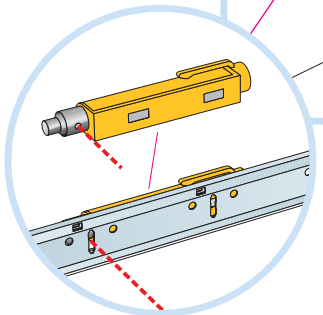

≤300 (12'')



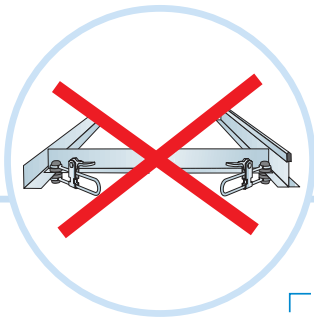
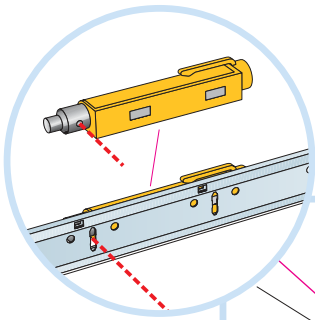

11

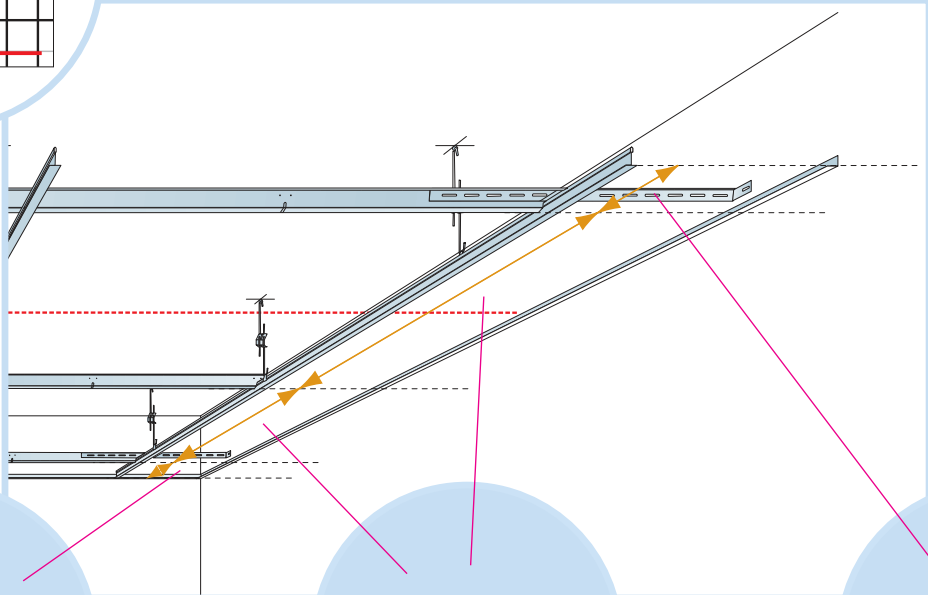
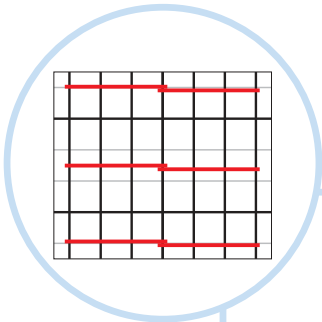
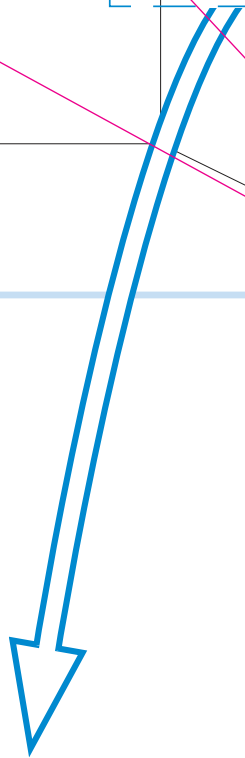
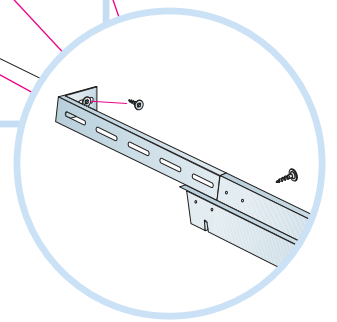
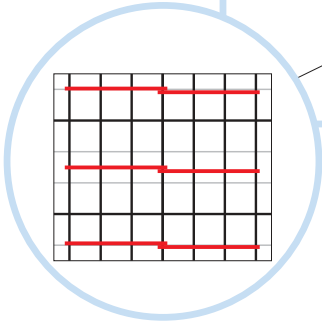
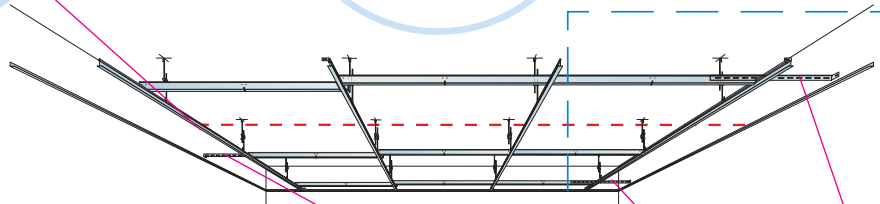

≤300  
(12")

1500  
(60")

≤300  
(12")

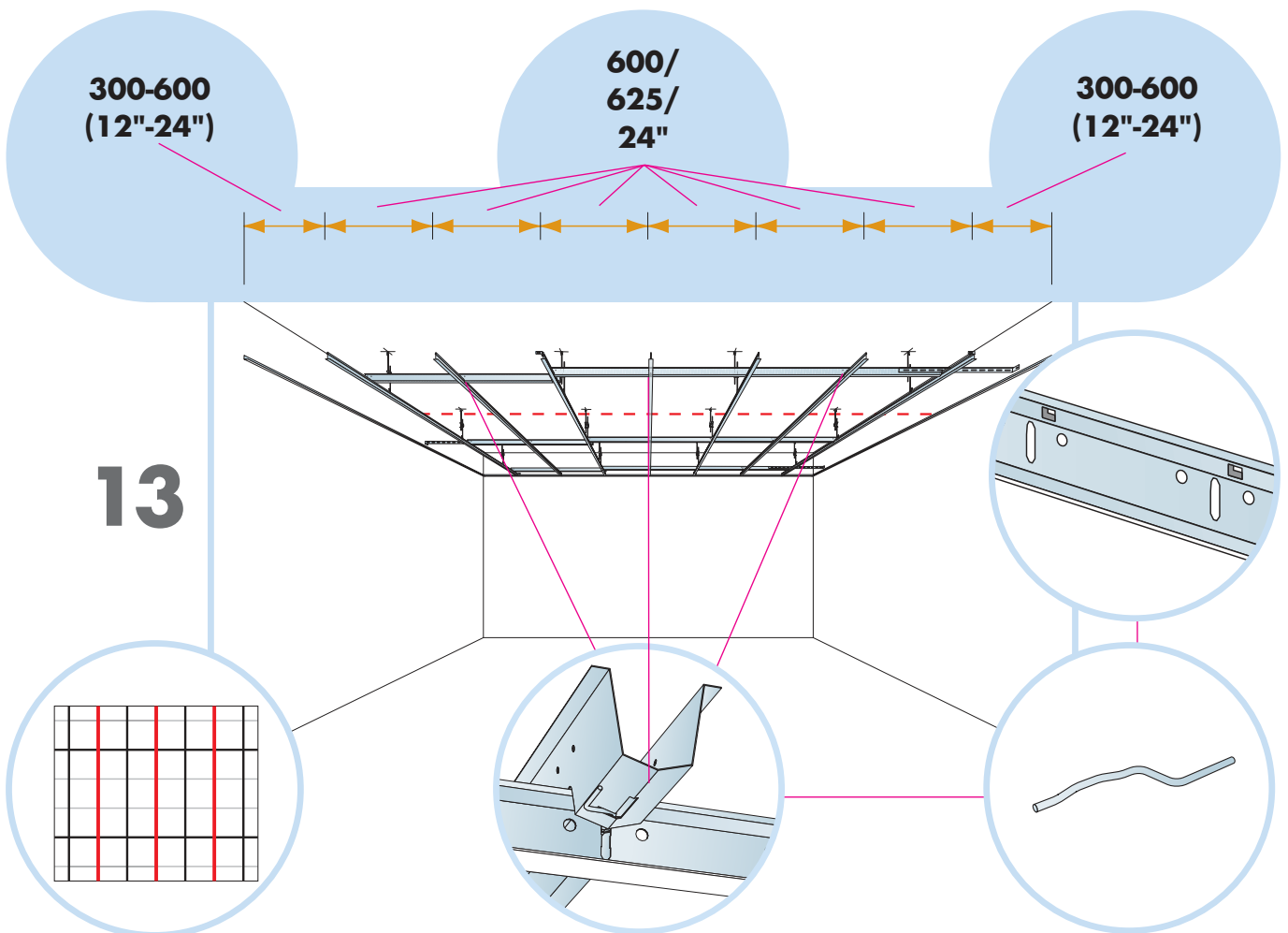
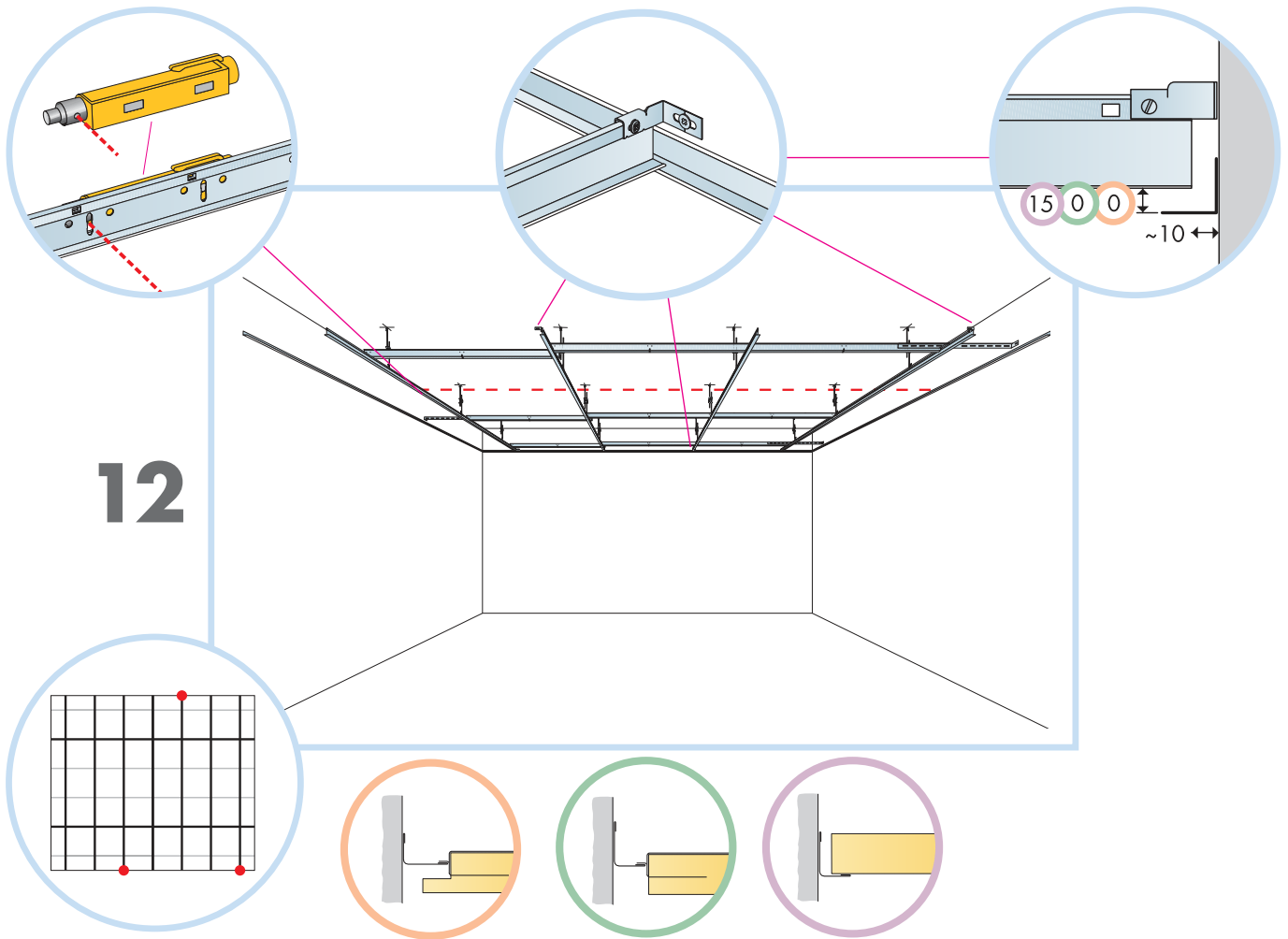

□ **600x600/  
625x625/  
24"x24"** → **14**

□ **1200x600/  
1250x625/  
48"x24"** → **18**

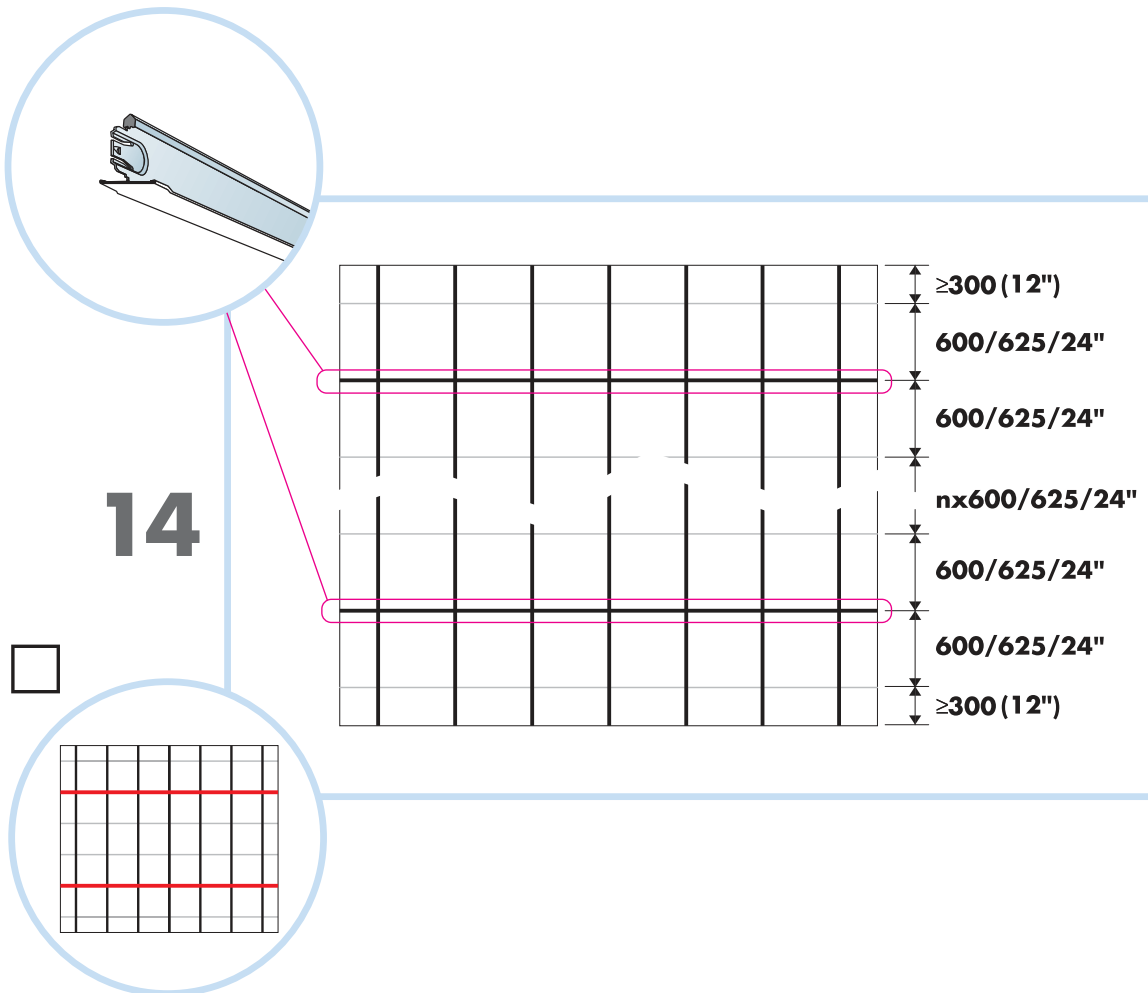

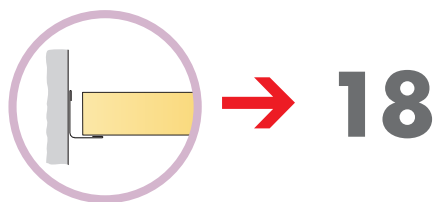
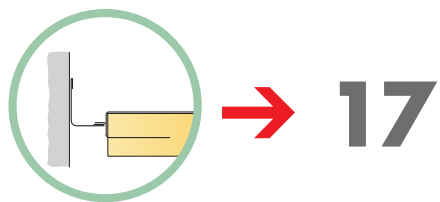
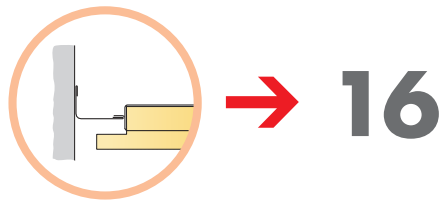
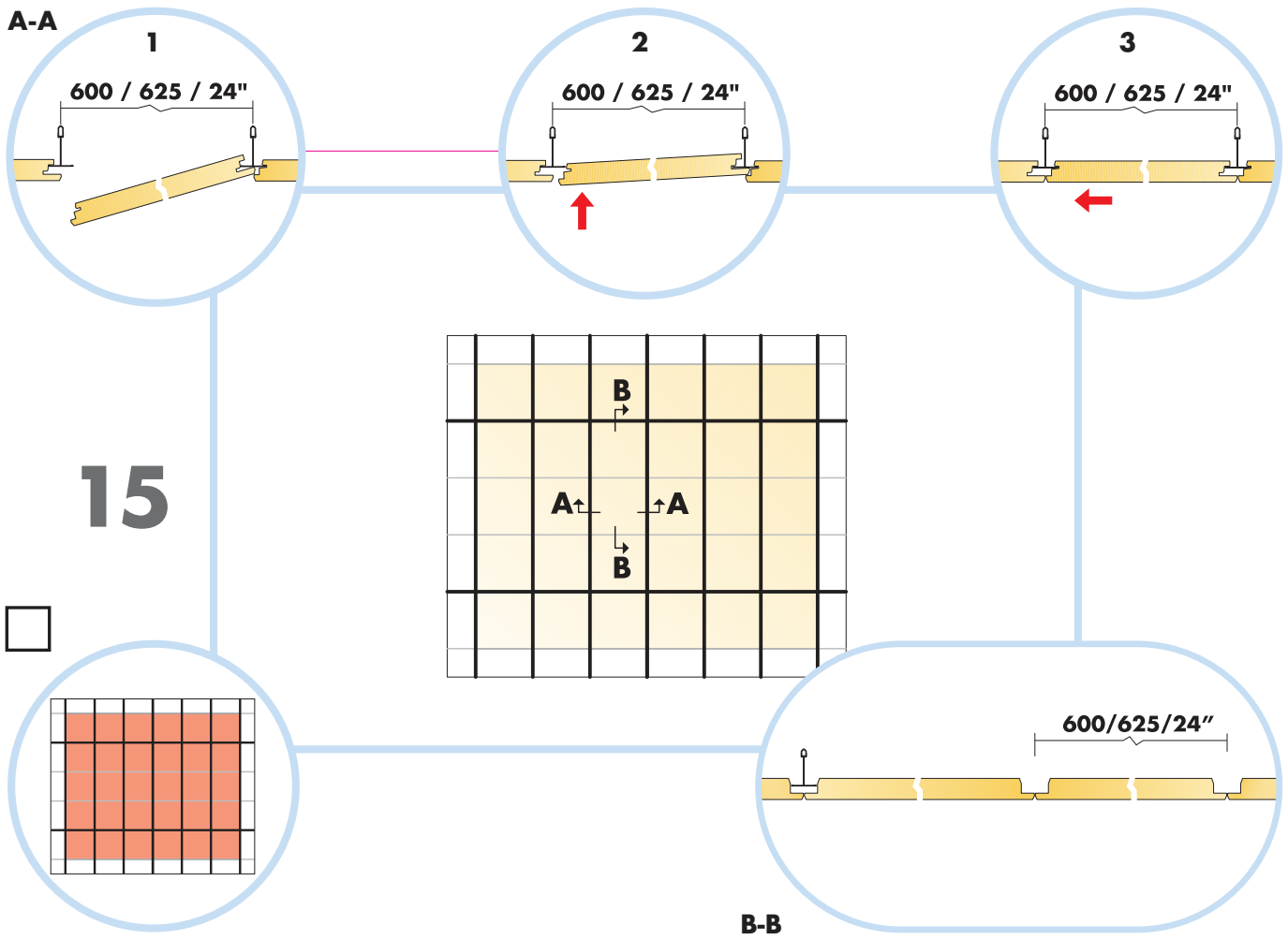

Cutting tool 0991

C-C

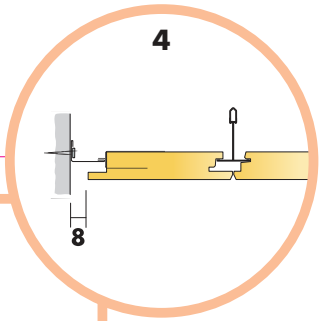
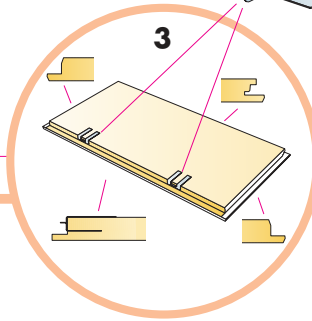
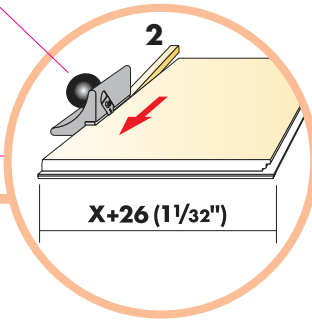
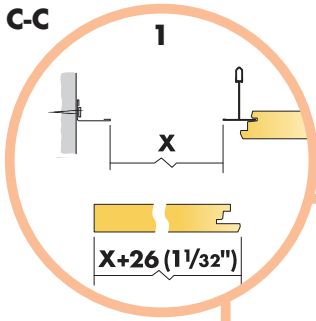

16

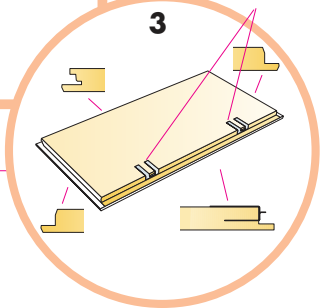
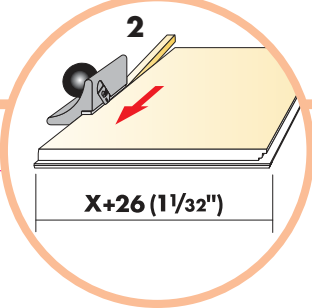
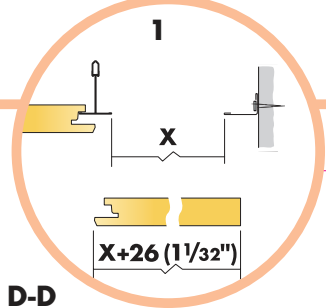
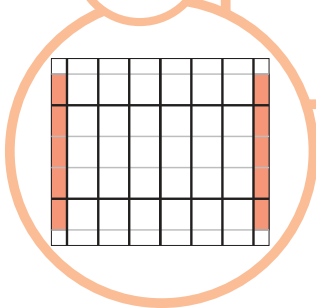
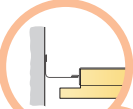
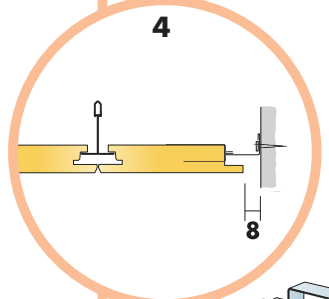
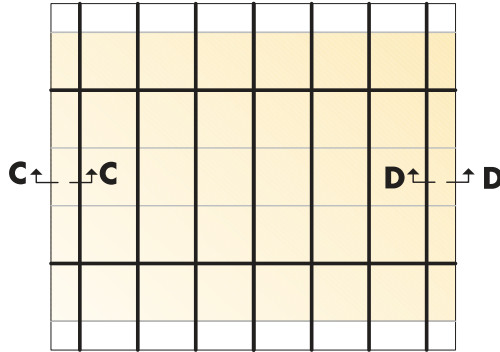

E-E

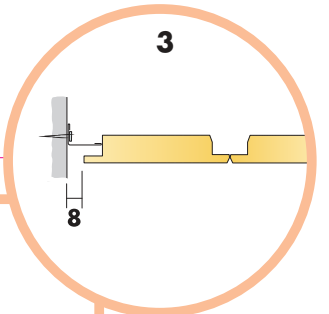
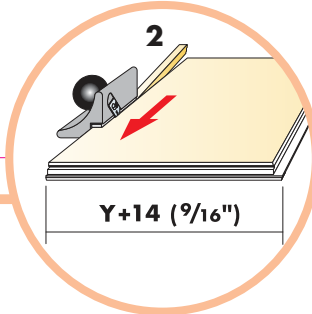
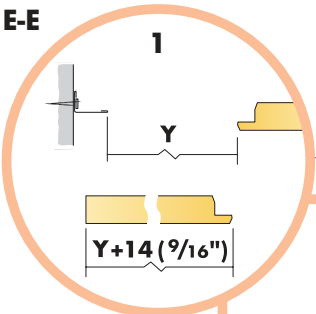

16<sup>1</sup>

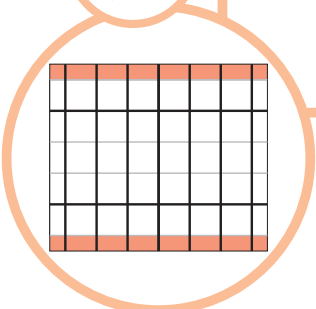
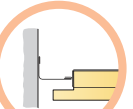
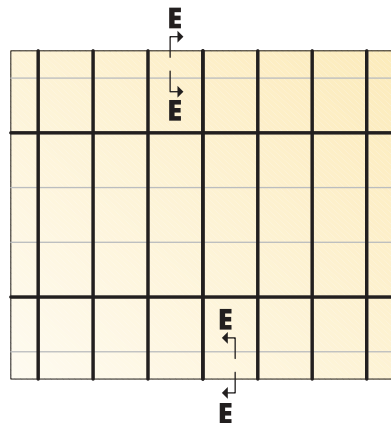

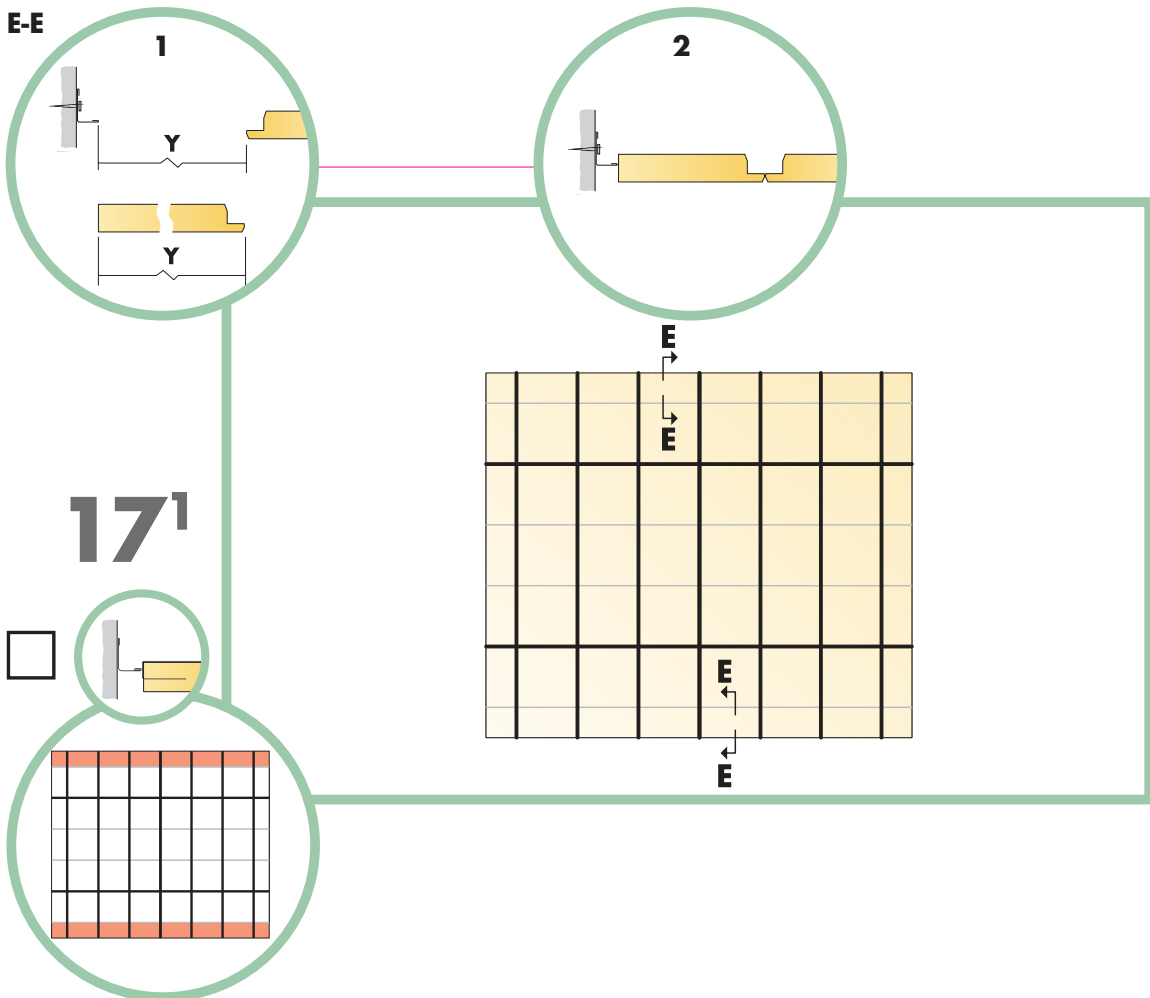
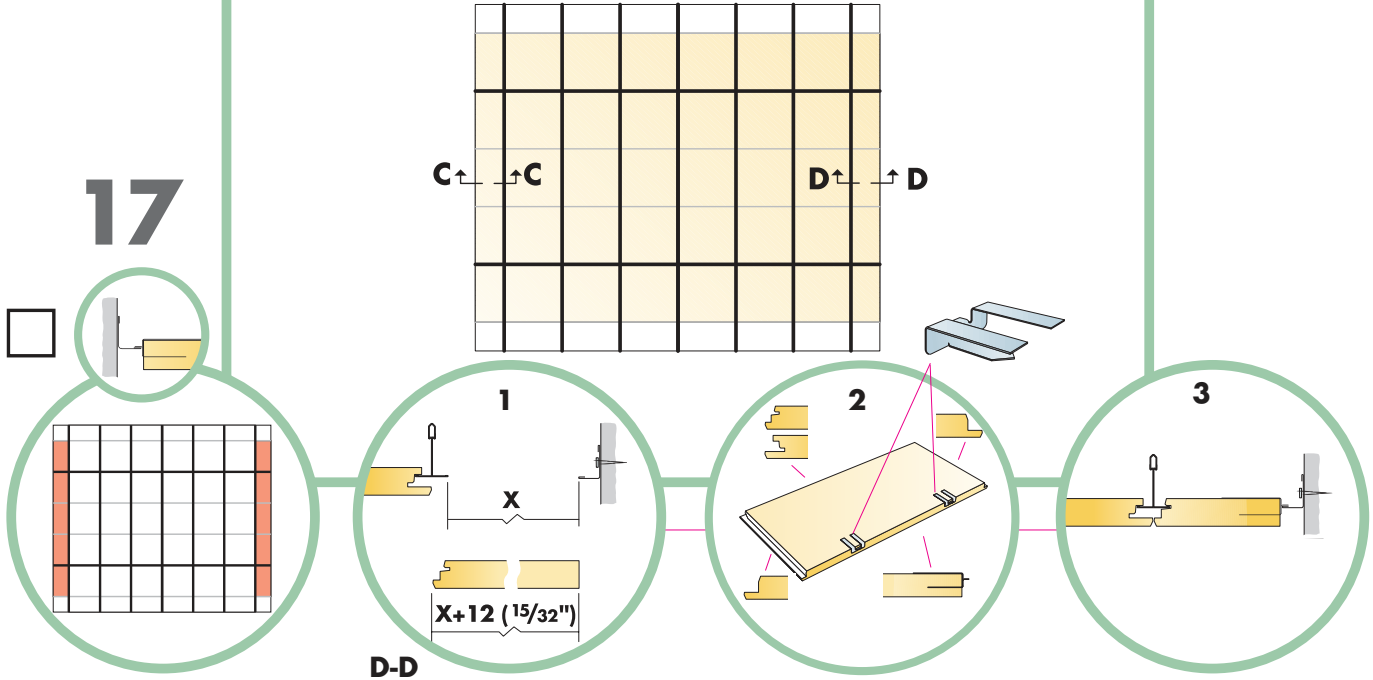
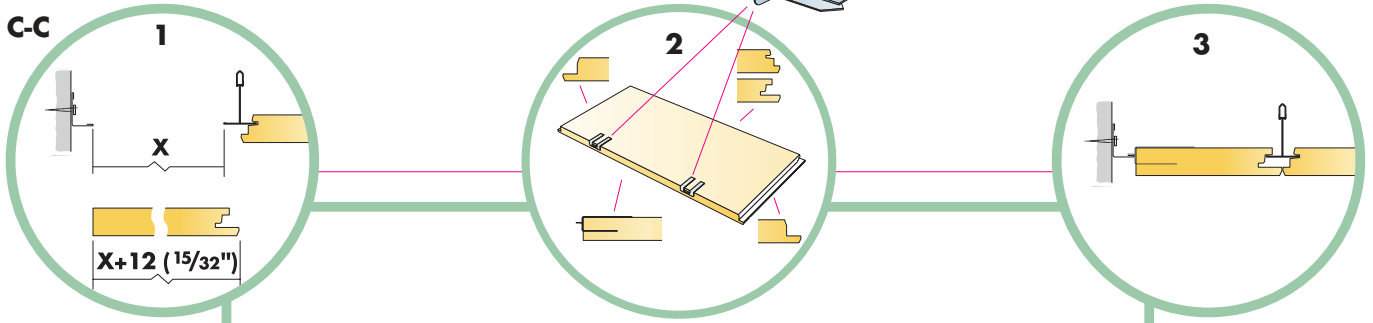

C-C

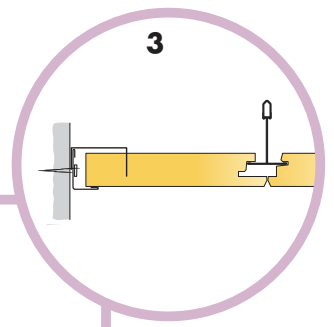
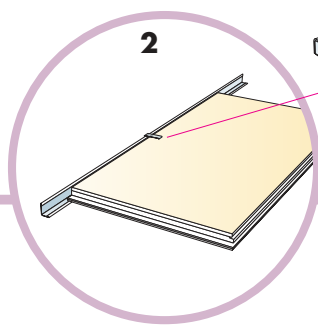
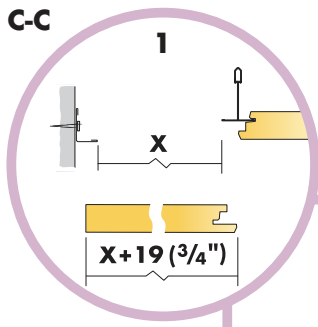

18

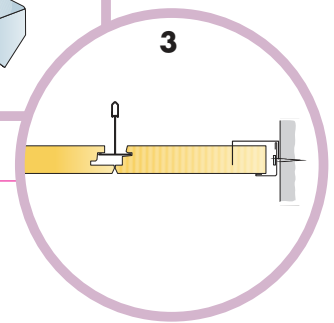
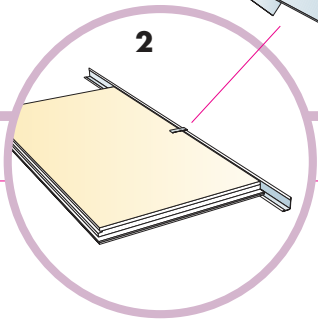
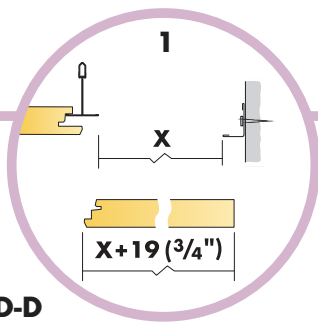
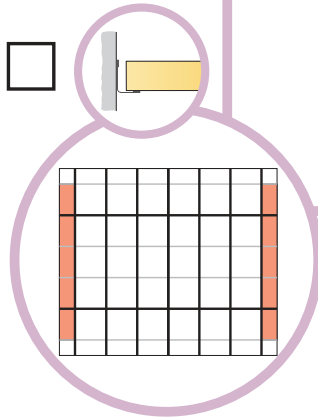
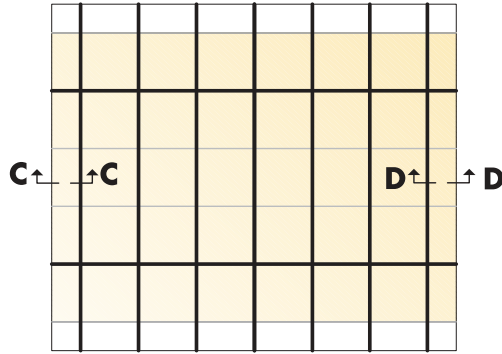

E-E

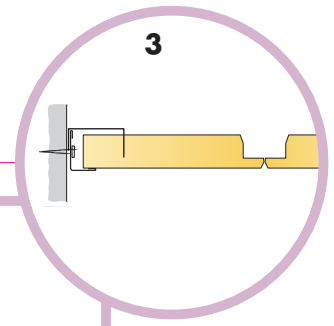
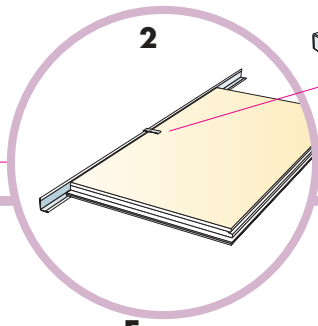
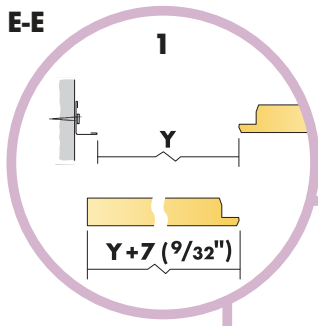

18'

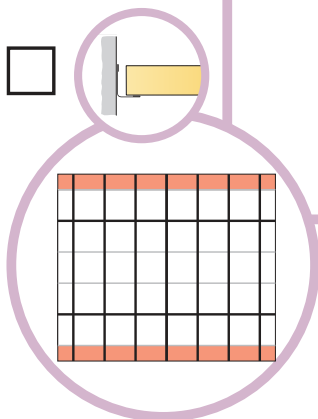
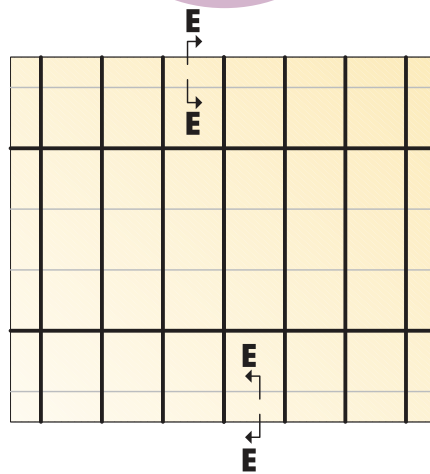

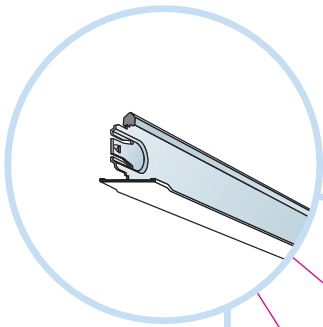

19

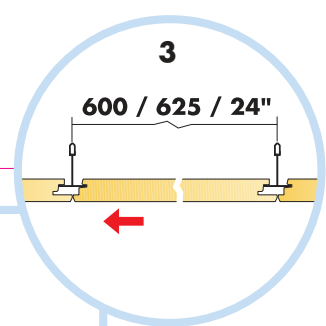
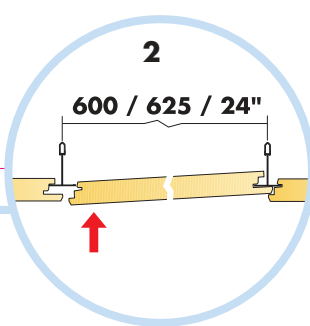
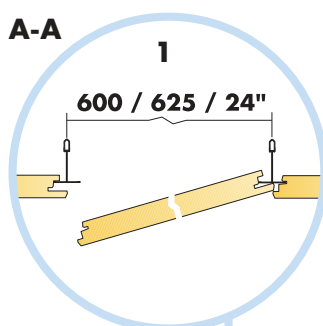
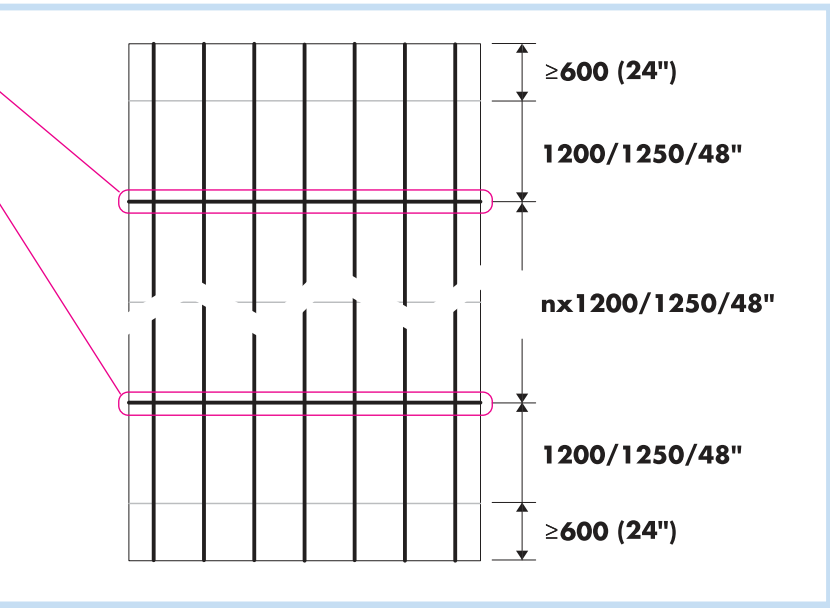
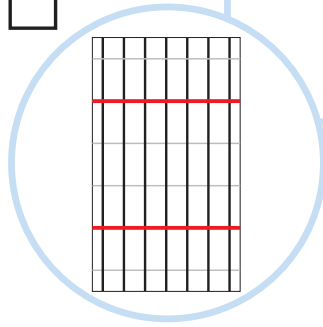

20

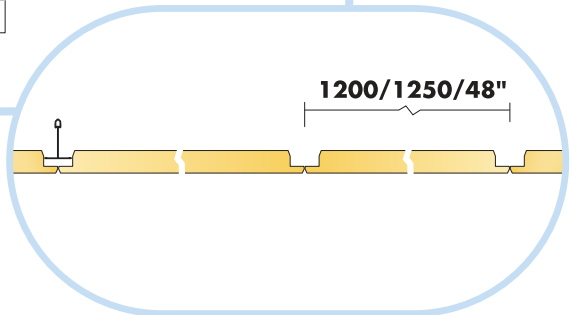
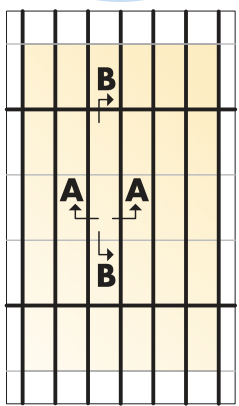
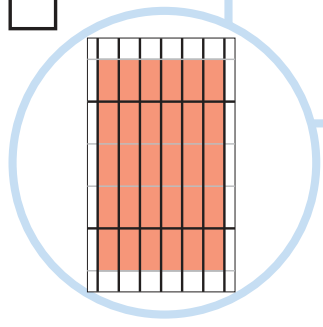



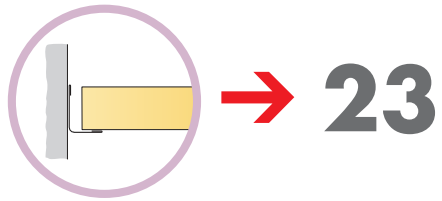
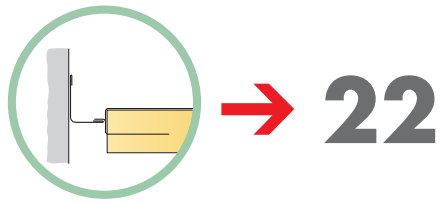
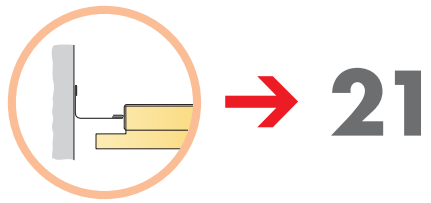

Cutting tool 0991

C-C

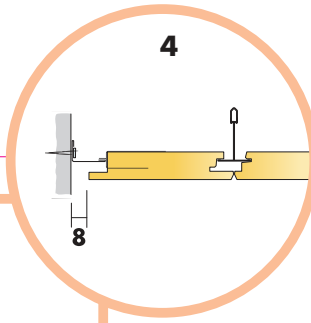
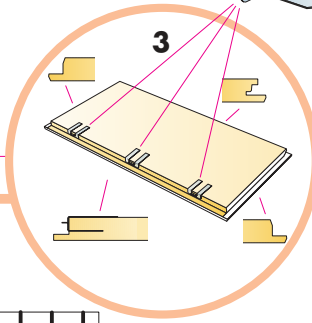
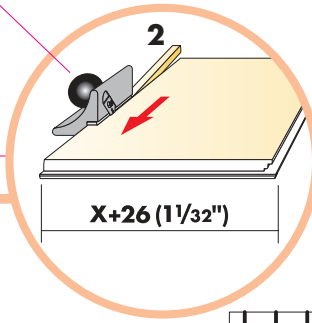
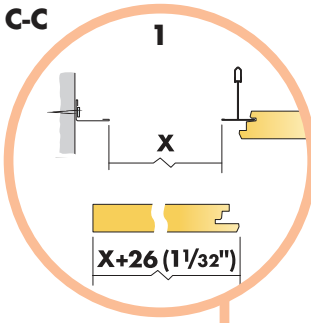

# 21

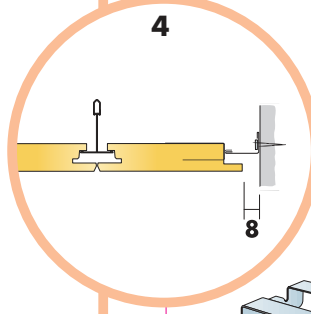
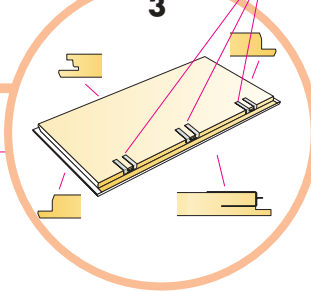
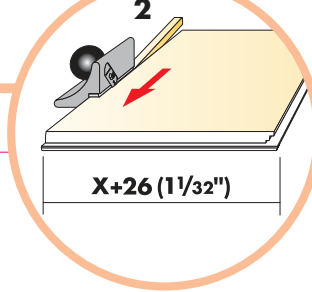
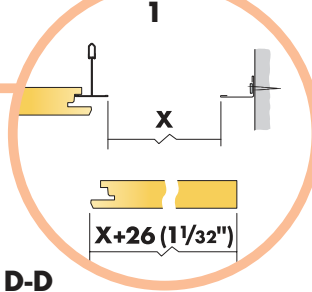
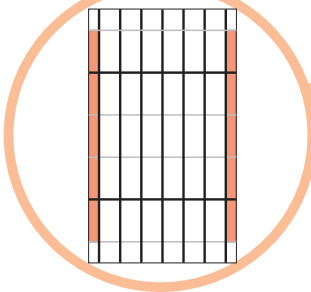
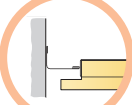

D-D

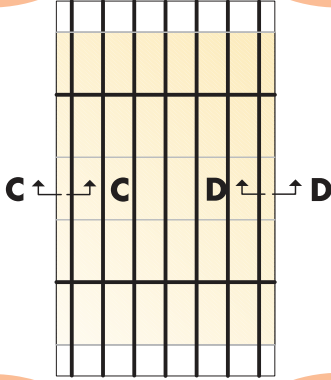

E-E

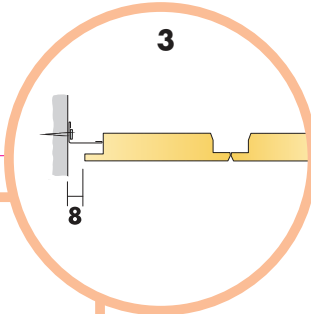
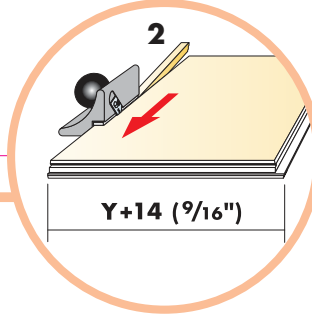
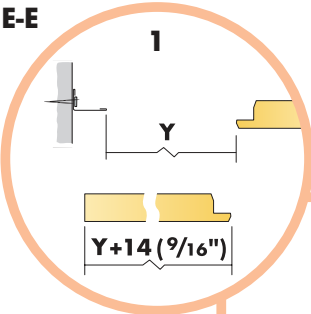

# 21'

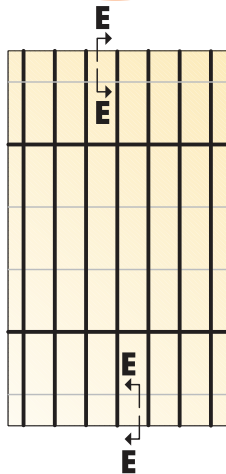
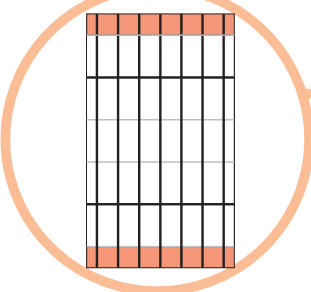
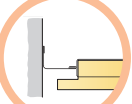

C-C

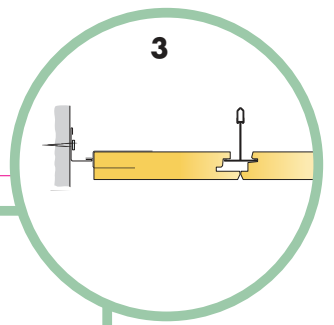
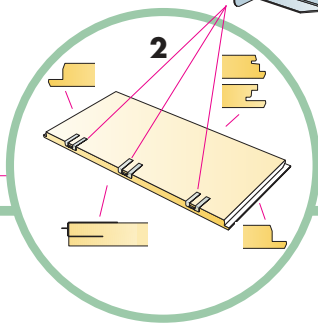
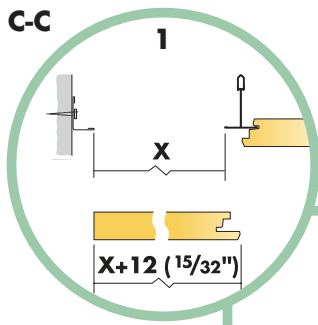

22

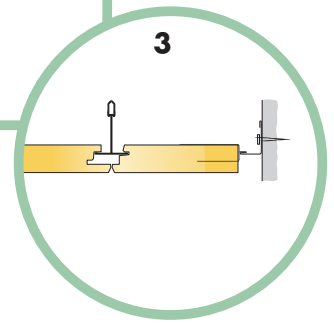
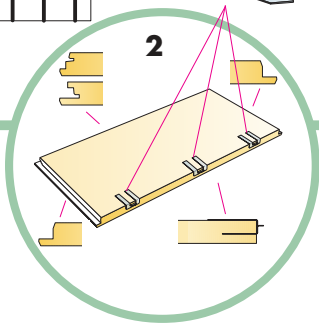
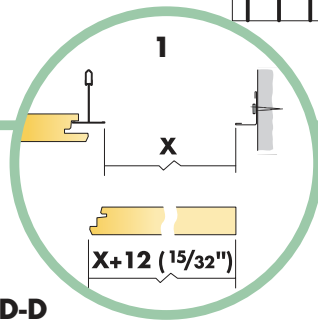
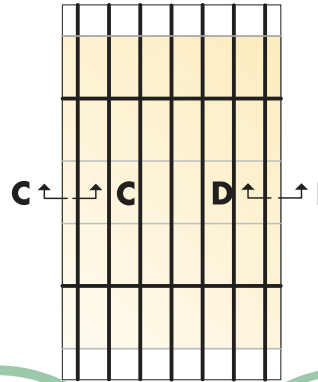
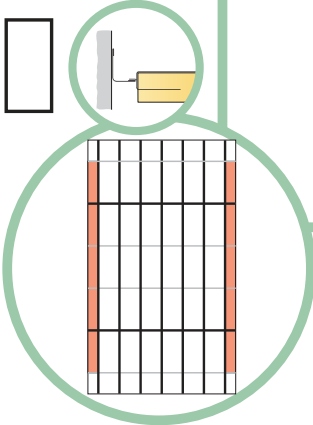

D-D

E-E

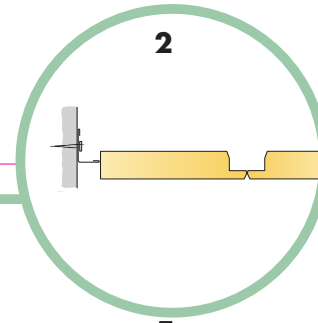
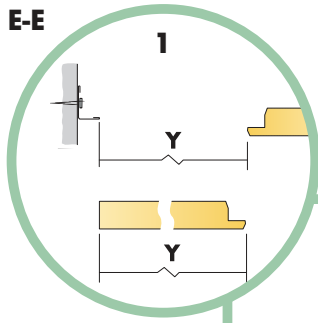

22<sup>1</sup>

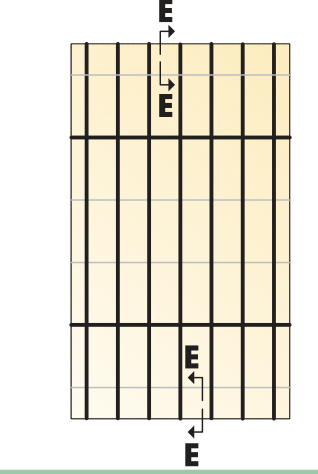
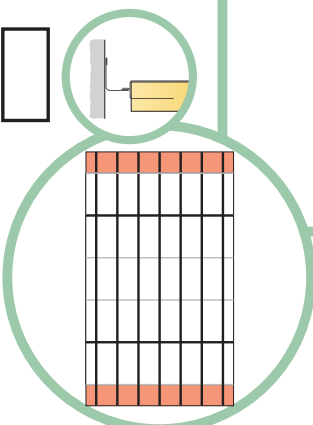

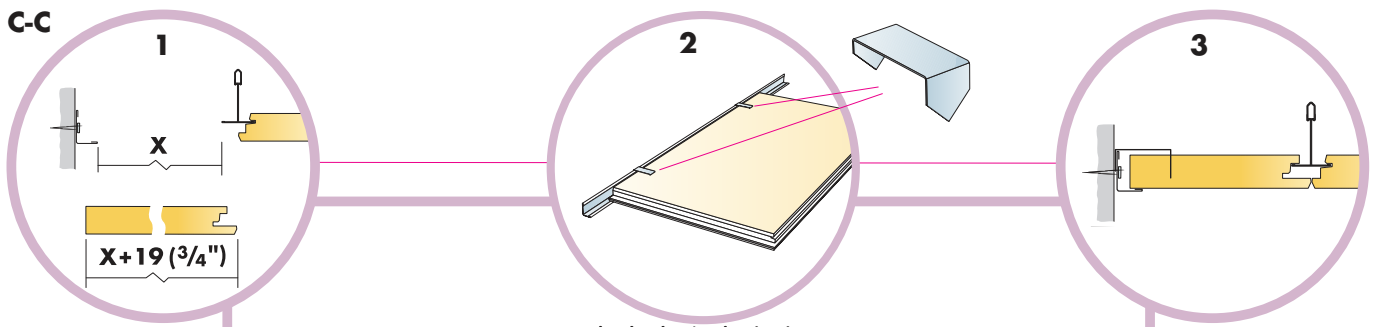

**23**

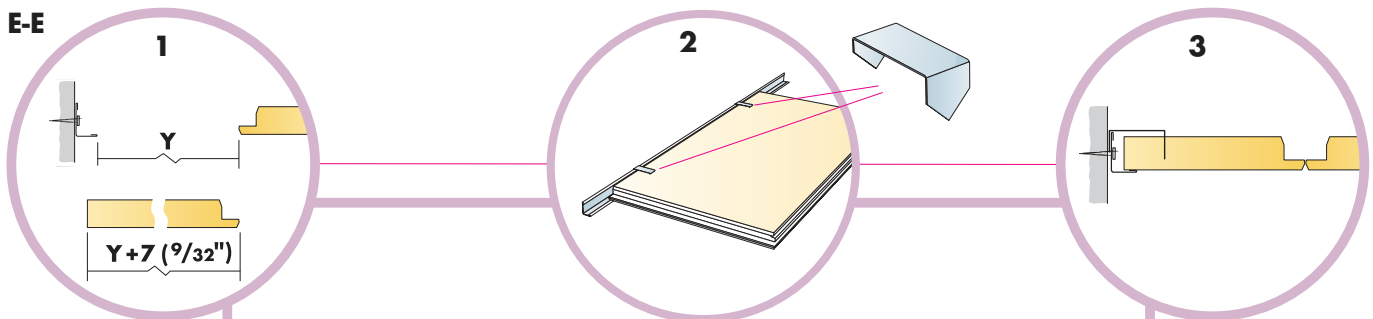
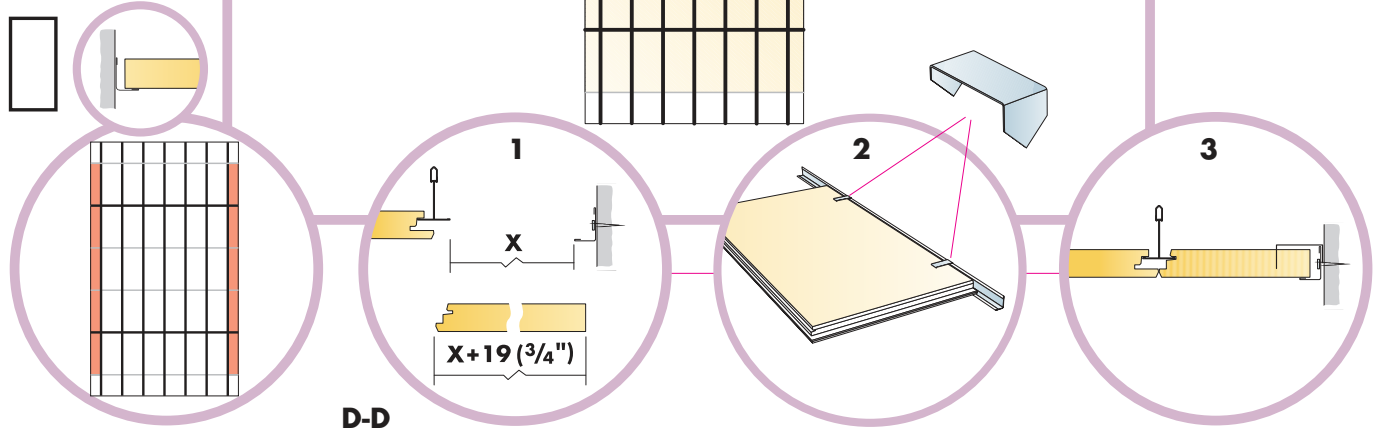

**23<sup>1</sup>**

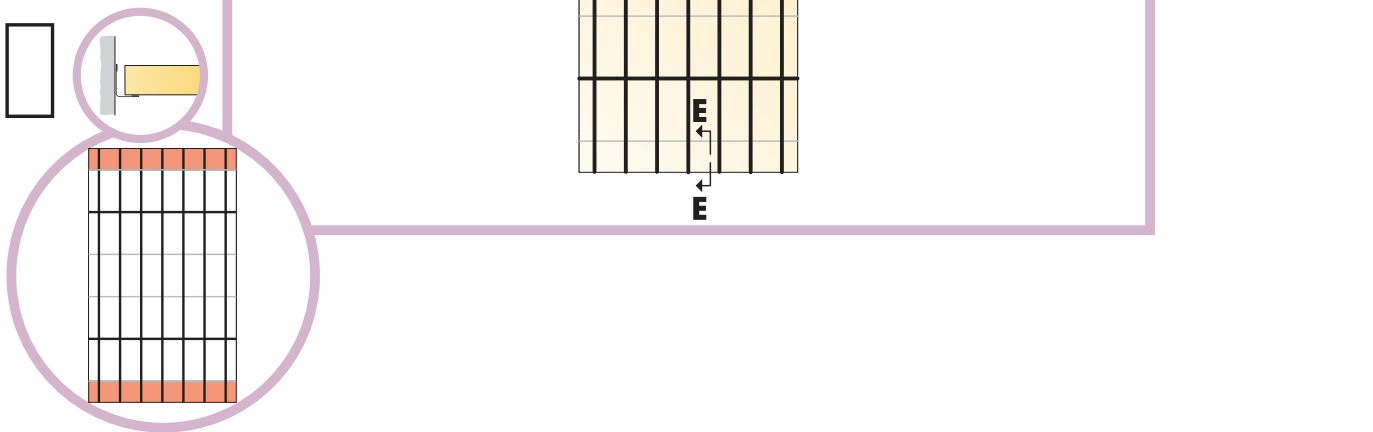

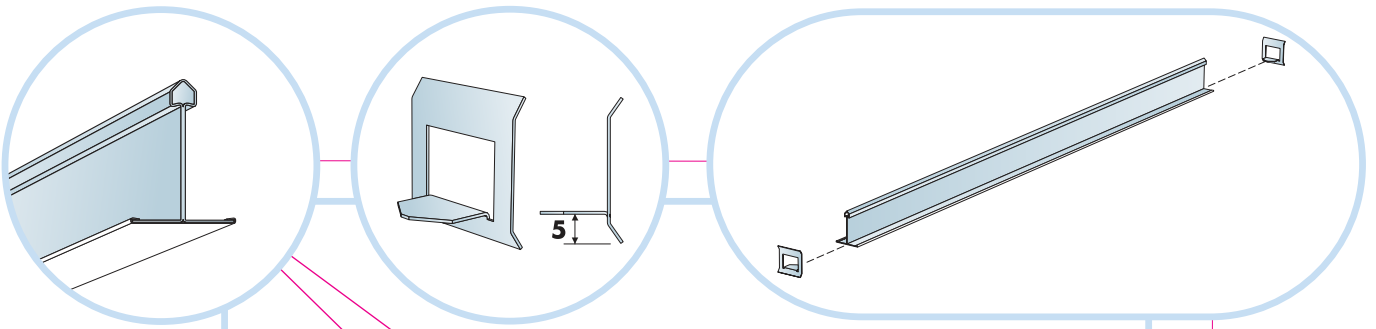

**24**

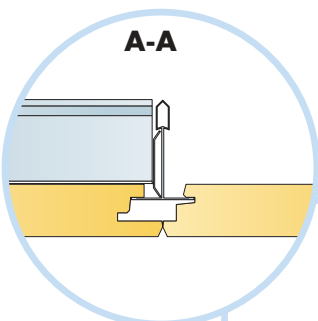
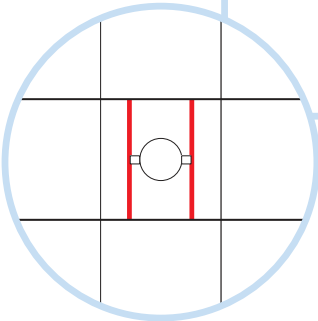
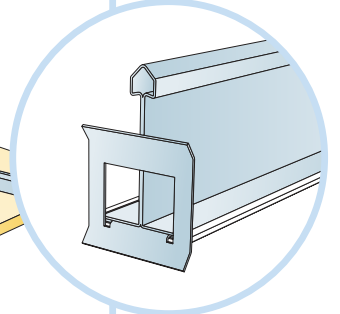
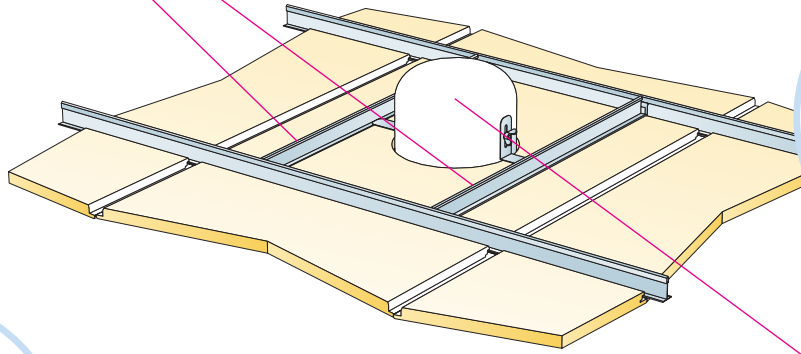

**Alt 1**

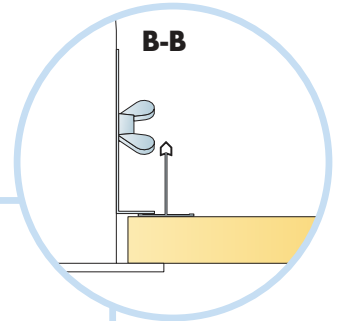

**25**

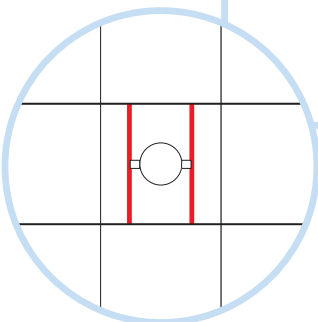
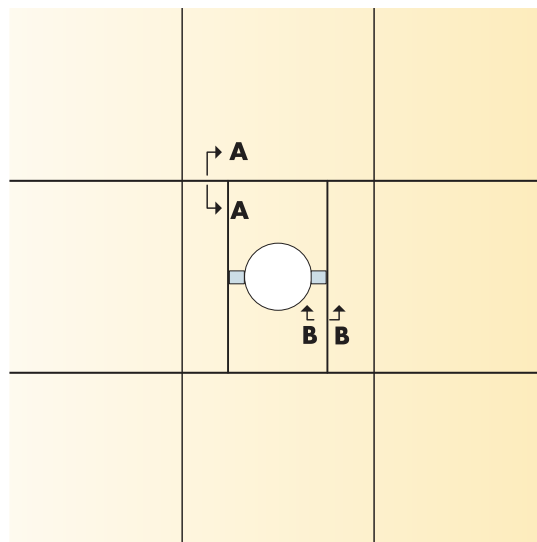

Alt 2

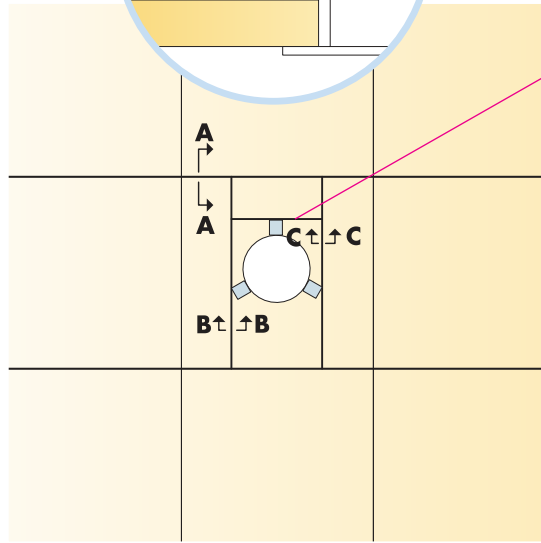
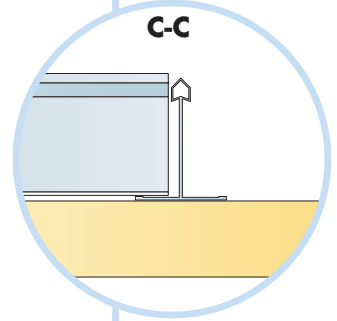
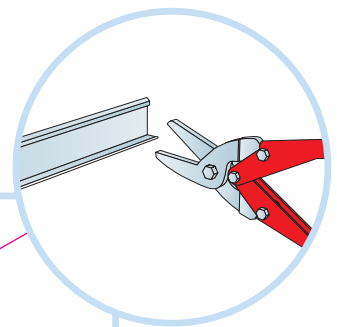
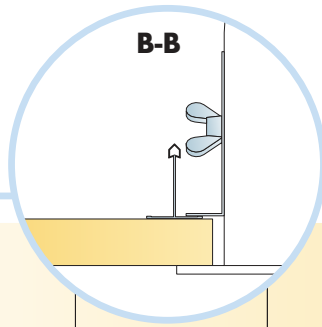
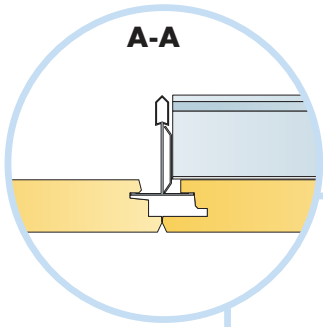

26

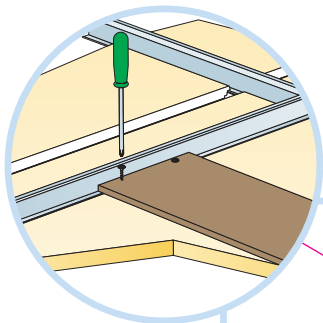
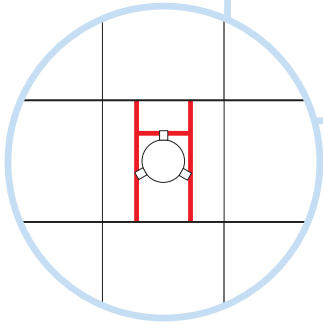

Alt 3

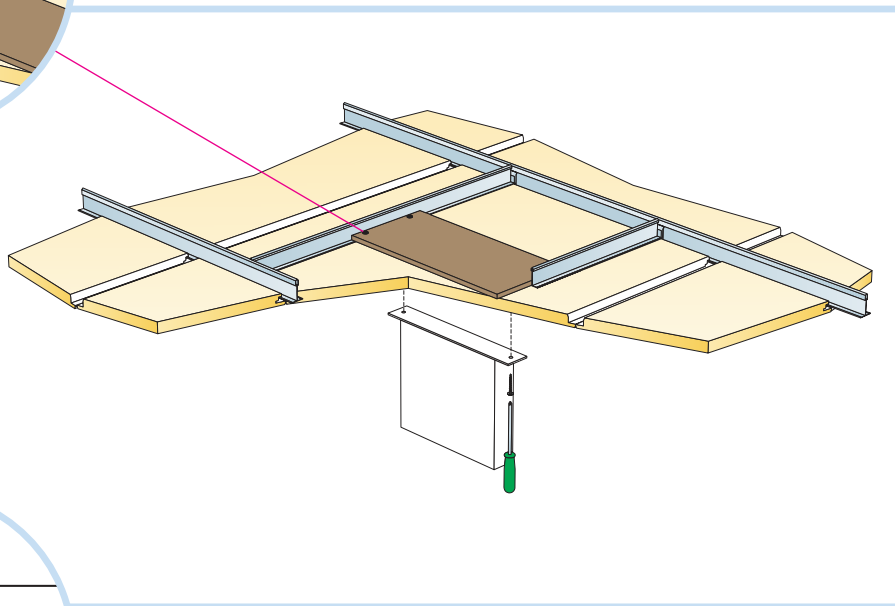

27

