

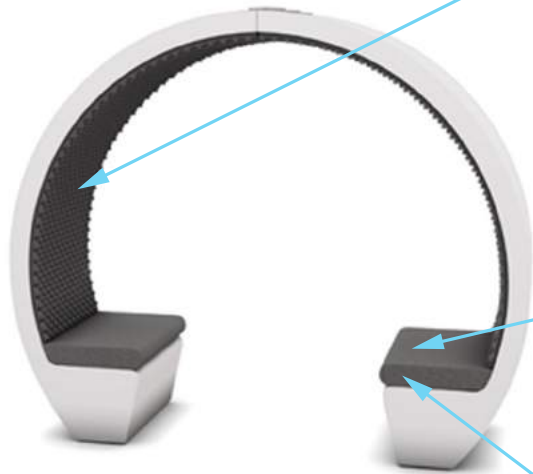

Technical specification

Standard Specification

Our Meeting Pods are modular in design, available in sizes from 2 to 8 person with a full range of accessories.



Acoustic Foam Lining- convoluted foam (egg crate pattern) with a total thickness of 40mm (10mm base/30mm rise) in charcoal grey, designed to control the acoustics and reverberation characteristics of recording studios, auditoriums, home cinemas etc.

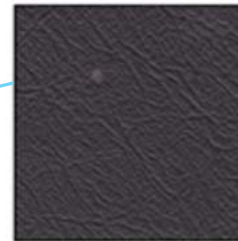

EC 04 (graphite)

Seat Material – Textile supported expanded vinyl, overall weight 660 gsm.

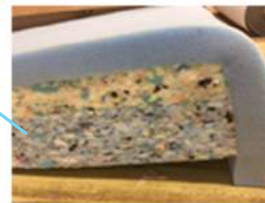

Seat Foam – 3", 6lb reconstituted foam with 1" blue topper. All foam materials comply BS 5852 flammability performance requirements and cigarette/match ignite test.

Dimensions

2 person meeting pod

- Structure: 50kg
- Table & Leg: 30kg
- LED lights and lighting track 10kg

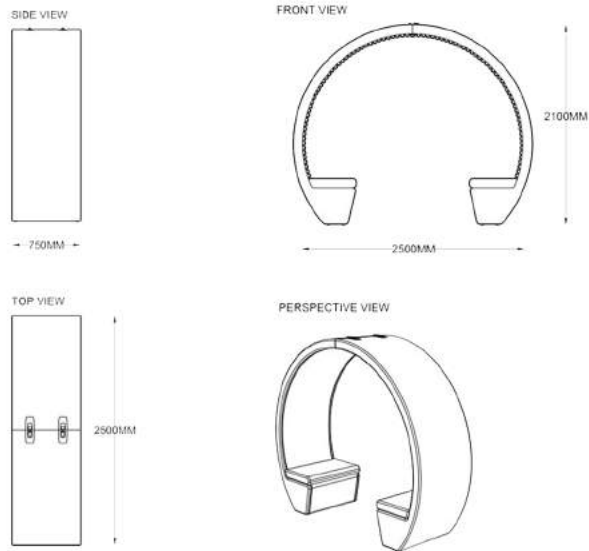

6 person meeting pod

- Structure: 150kg
- Table & Leg: 90kg
- LED lights and lighting track: 30kg

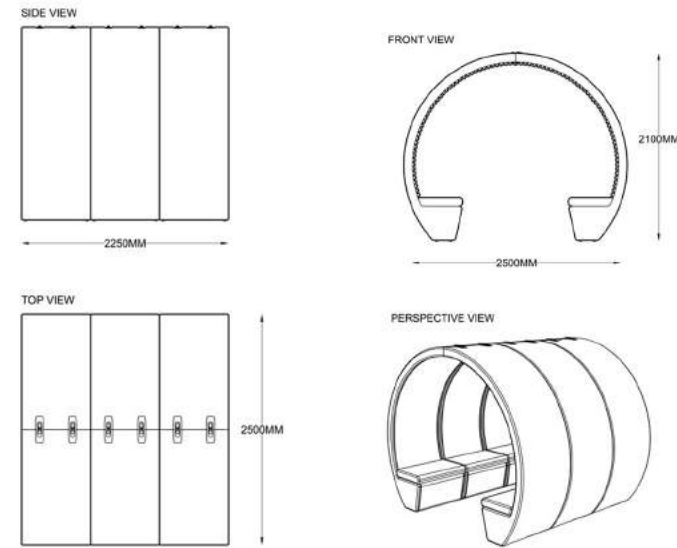

4 person meeting pod

- Structure: 100kg
- Table & Leg: 60kg
- LED lights and lighting track: 20kg

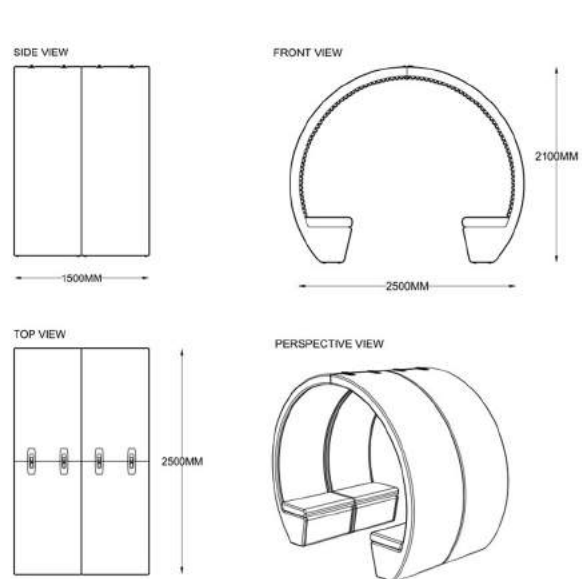

8 Person meeting pod

- Structure: 200kg
- Table & Leg: 120kg
- LED lights and lighting track: 40kg

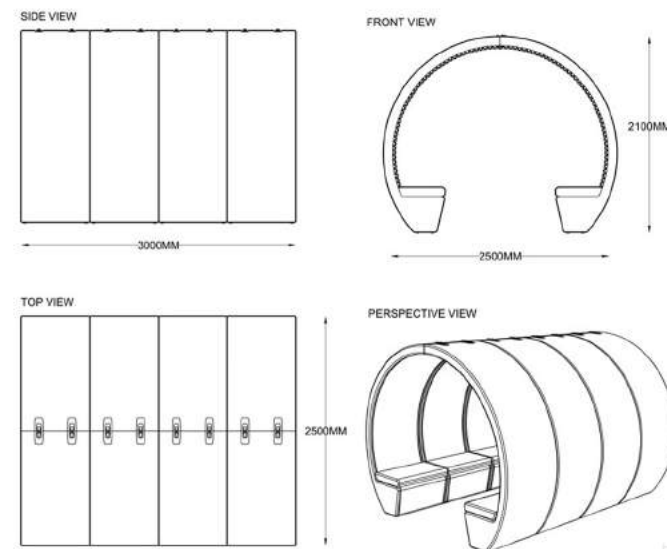

Accessory options & Accessory weights

Options



- **Tables -**
White textured formica table top with chamfered edges, cast steel table base powder coated white textured finish
Size and profile variations dependent on pod size and open/enclosure configurations



- **Full glass front enclosure -**
Double-glazed wings with composite double-glazed door
• **Weight = 120Kg**
Frameless single-glazed wings with frameless glass double doors
• **Weight = 206Kg**



- **Acoustic Back Panel -**
Acoustic foam wings with central core
• **Weight = 100Kg**



- **Air Ventilation-**
For meetings pods with back panels and full glass enclosures an airflow system is fitted which is operated from the light switch. Standard Airflow system with silent running extractor fan will exchange up to 95m³ of air per hour



- **Glass Back Panel -**
Double-glazed wings with solid central core back panel
• **Weight = 110kg**
Frameless single-glazed wings with solid central core back panel
• **Weight = 94kg**



- **Premium Airflow system-**
An EM200 Ruck will exchange up to 1300m³ of air per hour, with a 3 speed variable control, the unit is housed in the table leg



- **Partial glass front enclosure -**
Double-glazed wings with open doorway
• **Weight =75Kg**
Frameless single-glazed wings with open doorway
• **Weight =86Kg**



- **Air Conditioning -**
Air conditioning cooling/heating unit with 7000 BTU (1.8KW) capacity with dehumidifier function and 24h timer and housed in the table leg

Bespoke options- Colours

Internal Options- Foam Premium Colours (5 colours)



Ral 5010
Gentian Blue



Ral 2009
Traffic Orange



Ral 7012
Basalt Grey



Ral 9005
Jet Black



Ral 3016
Coral Red

-Foam Bespoke Colours available by RAL Specification

External options- Shell Premium Colours



Ral 7016
Anthracite Grey



Ral 9005
Jet Black



Ral 9002
Grey White



Ral 6025
Fern Green



Ral 7001
Silver Grey

-Shell Bespoke Colours available by RAL Specification

Fabric Options

- Camira Halycon Poplar Range
- Camira Era Range
- Camira Blazer Range
- Camira Xtreme Range
- Camira Synergy Range
- Camira Gravity Range
- Camira Advantage Range
- Camira Vita Range

-Fabric wrapped seat foam

-Fabric wrapped bolstered foam lining

Power Options

Main Power connection



- 1 x double power point with 2 x USB connectors is fitted to the back panel (or into the seat base if no back panel is selected) – 2m connection lead with 13amp fused plug centre of back panel.

Premium Pendant Lighting



- Tala pendant lighting system with filament lamps made of mouth blown glass, achieves 540 lumens.

Tech Pack



- Option for pods with power connection and fitted back panel. Screen hanging arm, additional single power point at screen hanging level, HDMI connector and ethernet to accommodate screen hanging with pod.

Acoustic Upgrade



- Rockwool insulated shell cavities and pod flooring for enhanced acoustic properties.

Standard Lighting



- Infra red sensor switch. LED cable lighting in Chrome with adjustable spotlight heads, using 85% less energy and lasting up to 20 times longer than incandescent bulbs.

Warranty



- A five year warranty is supplied on the composite structure of the meeting pods covering normal use for the purposes of meetings. In addition the benefit of any manufacturers' warranty given by a third party supplier of Goods will be assigned to the Buyer. No liability will be accepted for any defect arising from fair wear and tear, wilful damage, negligence, misuse, alteration or repair without the Seller's approval in writing.

Installation information

■ Installation time



-Open ring pods – Up to 2 hours per pod



-Pods with back panel – Up to 4 hours per pod



-Fully enclosed pods – Up to 6 hours per pod

■ Installation tools

No power tools are used for the installation process ensuring a non disruptive, quiet installation that can be completed during working hours.

■ Installation requirements

- Local parking
- Access to the building
- Completion of pre-installation questionnaire